

AirLINE and AirLINE Quick – Modular pneumatic valve unit

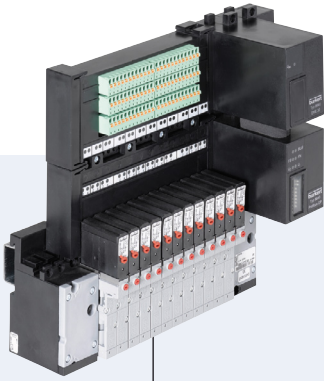

Type 8640 can be combined with...



Type 8032
Switch



Type 6212
Solenoid valve



Type 2012
Process valve



Type 8695
Control head

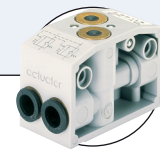



Type 0498
Double pilot controlled
check valve

- Compact design
- Modular configuration
- Higher flexibility in control cabinet due to AirLINE Quick
- Simple exchange of valves (with option “P-shut-off” – also possible during operation)



The 8640 valve unit system is designed to solve diverse and complex control problems due to its systematic modular construction and combination of pneumatic and electrical interfaces. By putting together a row of pneumatic modules with different numbers of valves, 2 to 24 valve functionalities may be realized on one valve unit.

Electrical connectivity is achieved by either fieldbus interfaces, common connection (parallel connection technique) or multipin interfaces. The valves allow different applications to be covered. Bodies and connection modules are made of high-quality plastic (polyamide) and are easy to assemble by means of the built-in snap connectors.

Specification	Type 0460/6524/6525 	Type 6526/6527 	Type 5470 
Mounting dimensions	11 mm	16.5 mm	18 mm
Ambient temperature	0 to +55 °C (by use of Type 0460: 0 to +50 °C)	0 to +55 °C	-10 to +55 °C
Pressure range	Vac. – 10 bar	Vac. – 10 bar	2 – 10 bar
Operating voltage	24 V DC	24 V DC	24 V DC
Voltage tolerance	± 10%	± 10%	± 10%
Degree of protection	3 acc. to VDE 0580	3 acc. to VDE 0580	3 acc. to VDE 0580
Duty cycle	Continuous operation (100% ED)	Continuous operation (100% ED)	Continuous operation (100% ED)
Circuit functions	C and D (3/2), H (5/2), H (5/2) Impulse, L (5/3) in middle position all ports closed N (5/3) in middle position all ports vented	C and D (3/2), H (5/2),	C and D (3/2), G (4/2),
Flow rate	300 l/min ¹⁾	700 l/min	300 l/min
Rated power	1 W	2 W, 1 W	1 W, 2 W, 3 W
No. of valve functionalities per unit	Max. 24	Max. 24	Max. 24
Feedback	Max. 32	Max. 32	Max. 32
Degree of protection	IP20 with terminals	IP20 with terminals	IP20 with terminals

¹⁾ Maximum flow rate depending on valve function - see tables on pages 5 to 9.

Continued on page 2

Specification	Type 0460/6524/6525 	Type 6526/6527 	Type 5470 
Electric Connection	<ul style="list-style-type: none"> Common connection (parallel connection) Multipin (D-Sub, 25 pin) Profibus-DP DeviceNet CANopen Internal bus extension by Profibus DP Profinet IO Ethernet I/P Modbus TCP 		
Total current with common connection with multipin connection with fieldbus connection	<p>as a function of the electrical connection technique max. 3 A (sum of current through individual valves) max. 3 A (sum of current through individual valves) + max. 3 A (repeater) $I_{TOTAL} = I_{BASE} + (n \times I_{VALVE}) + (m \times I_{REPEATER})$ n=quantity of valves, m=quantity of repeaters, I_{VALVE}= rated current of each valve I_{REPEATER}= rated current of each repeater, m x I_{REPEATER}=max. 650 mA I_{BASE}= 200 mA spec. base current Profibus-DP 200 mA spec. base current DeviceNet</p>		

The 8640 valve island system

Solenoid valves

0460/6524/6525

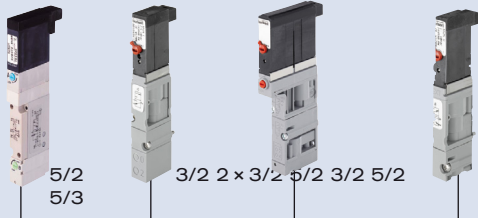

6526/6527

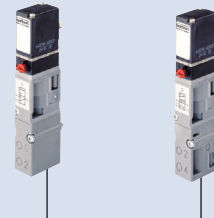

5470

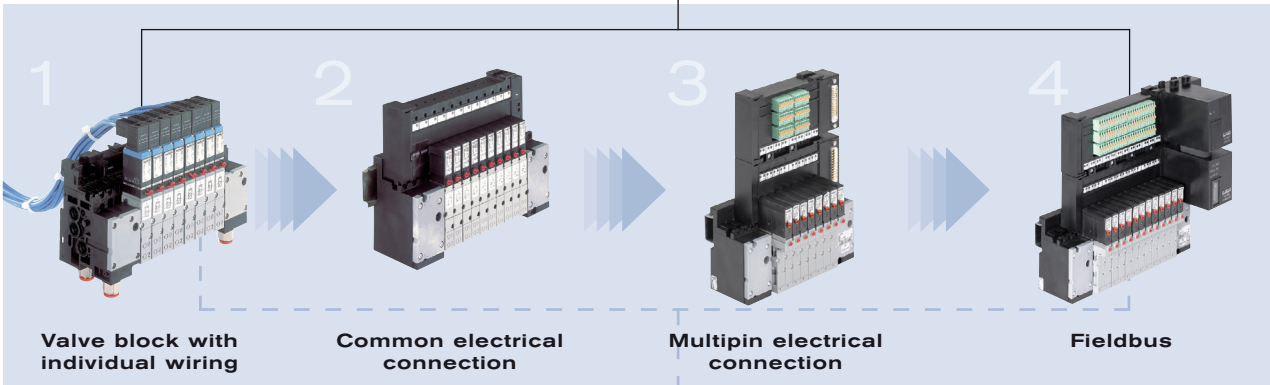

Valve block with individual wiring

Common electrical connection

Multipin electrical connection

Fieldbus

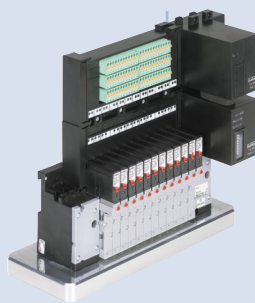

AirLINE Quick
Adapter for valve islands on the control cabinet floor or control cabinet wall

Application example

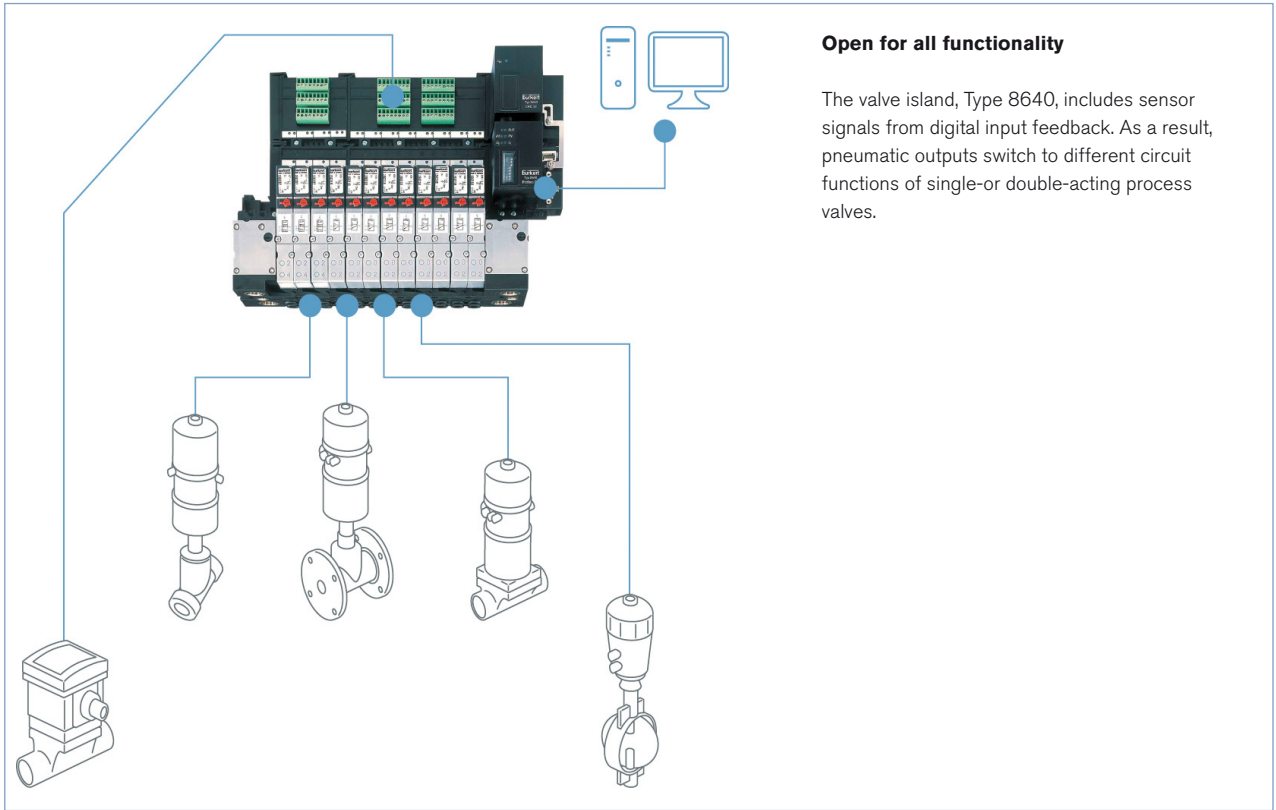
**Open for all functionality**

The valve island, Type 8640, includes sensor signals from digital input feedback. As a result, pneumatic outputs switch to different circuit functions of single- or double-acting process valves.

Examples 2D / 3D CAD data

Example 3D CAD model in 3D-Pdf format

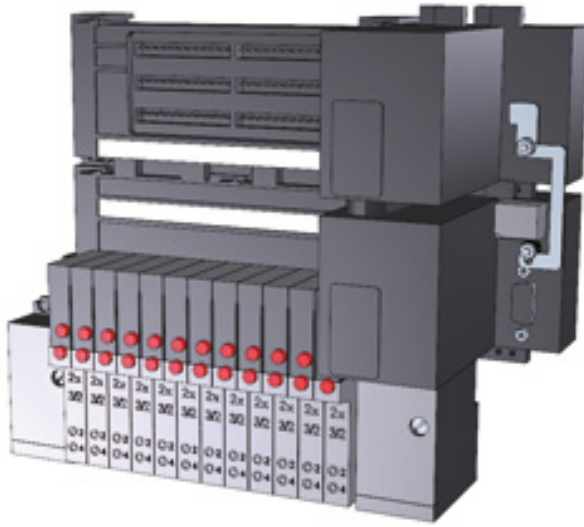

Examples 2D DXF drawings in different views

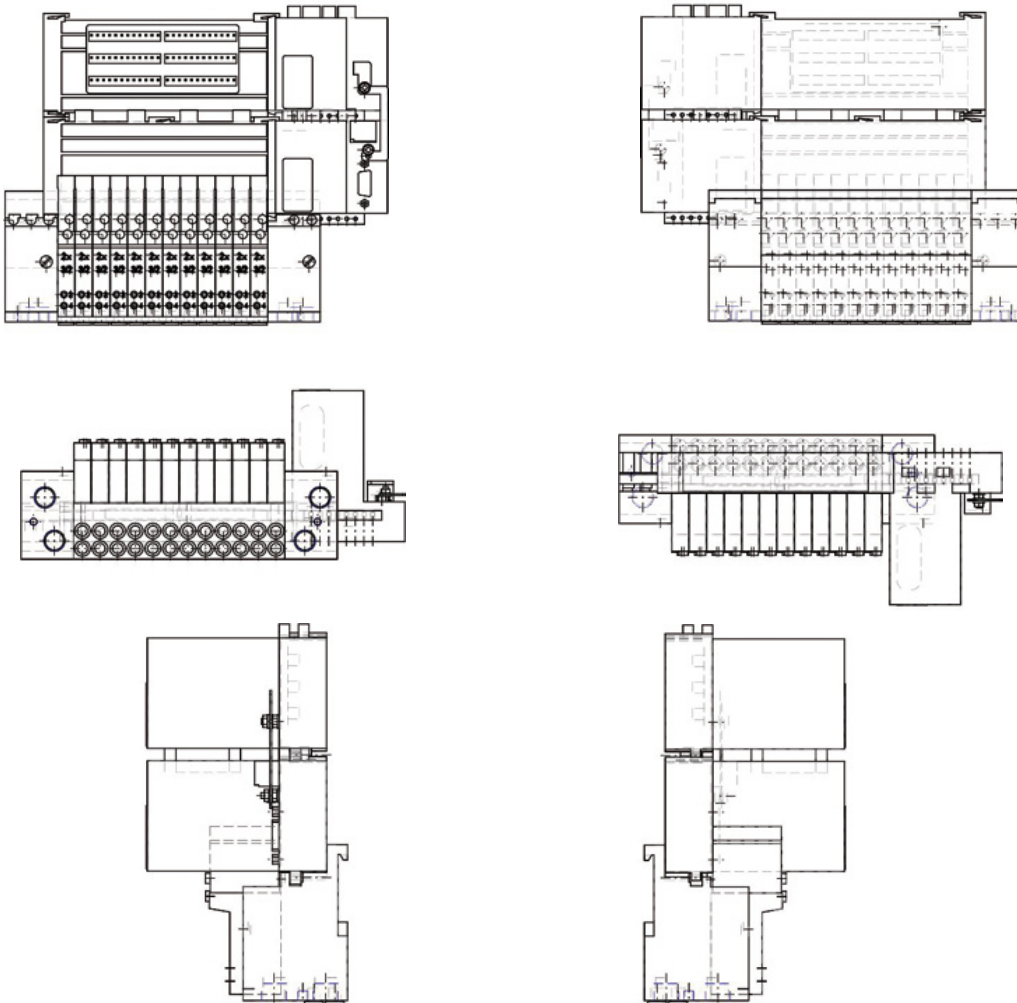

11 mm width per station Multi-way solenoid valve Types 6524 and 6525

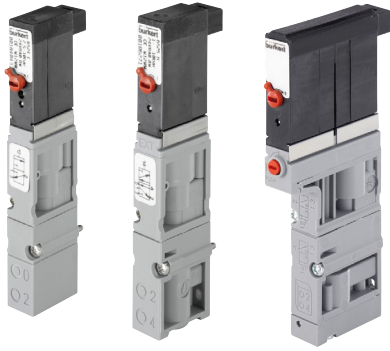

The solenoid valve Types 6524 and 6525 consist of a 6144 flipper pilot valve and a pneumatic seat valve. The flipper principle allows switching of high pressure at low power consumption and fast response times. The pilot valves are equipped with manual override as a standard. The 2 × 3/2 way valve version is a combination of two flipper pilot valves Type 6144 and a pneumatic seat valve.

Spezifikationen	3/2 way valve	2 × 3/2 way valve
Body material	PA (polyamide)	
Seal material	FPM, NBR	
Media	Lubricated and non-lubricated dry air, neutral gases (5 µm-Filter)	
Port connection	Flange for MP11	
Pneumatic module	Type MP11 with push-in connection dimension 6 mm, D1/4, M7	
Manual override	As a standard feature	
Voltage	24 V DC *	
Nominal power	0.8 W	2 × 0.8 W with reduction of power consumption
Duty cycle	Continuous operation (100 % ED)	
Elec. connection on valve	Rectangular plug 2 pin with raster 5.08 mm	Rectangular plug 3 pin with raster 2.54 mm
Mounting	With 2 screws M2 × 20	With 2 screws M2 × 28
Installation position	As required, preferably with pilot valve upright	
Flow rate: Q_{nn} value air [l/min]	Measured at +20 °C, 6 bar pressure at valve inlet and 1 bar pressure difference	
Pressure ranges [bar]	Measured as overpressure to the atmospheric pressure	
Response times [ms]	Measured according to ISO 12238	

* 10% residual ripple allowed

Order chart for valves

Circuit function	Orifice [mm]	Q _{nn} value air [l/min] ¹⁾	Pressure range [bar]	Response times		Voltage/Frequency [V/Hz]	Article no.
				Opening [ms]	Closing [ms]		
Circuit function C 3/2 way servo-controlled solenoid valve, normally closed, with manual override	4	300	Vak.-7	15	20	24 V DC *	186258
			1 - 10 ²⁾	15	20	24 V DC *	186257
			2.5 - 10	15	28	24 V DC *	184043
Circuit function D 3/2 way servo-controlled solenoid valve, normally open, with manual override			2.5 - 10	15	28	24 V DC *	184400
Circuit function H 5/2 way servo-controlled solenoid valve, pilot air and manual override	4	300	1.0 - 10 ²⁾	15	20	24 V DC *	186271
			2.5 - 10	20	28	24 V DC *	179938
Circuit function C 2 × 3/2 way servo-controlled solenoid valve, normally closed, with manual override	4	300	1.0 - 10 ²⁾	12	20	24 V DC *	186259
			2.5 - 10	12	20	24 V DC *	186260

¹⁾ With integrated HotSwap and/or non-return function, the flow rate is reduced.

²⁾ Version with auxiliary air.

³⁾ Version with integrated reduction of power consumption

* 10% residual ripple allowed







11 mm Anreihmaß: pilot valve Type 0460

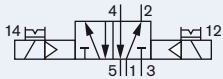

The solenoid valve Type 0460 consists of a pneumatic valve body fitted with a double coil pilot valve. The principle allows switching of high pressures together with low power consumption and fast response times. All valves are equipped with manual override as a standard.

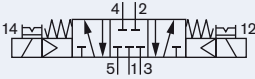
Technical data	
Body material	aluminium
Seal material	NBR
Medium	lubricated and non lubricated dry compressed air; neutral gases (5 µm-filter recommended)
Port connection	Flange
Pneumatic module	MP11
Supply port connection 1 (P), 3 (R), 5 (S)	G ¼ NPT ¼
Service port 2 (A), 4 (B)	push-in connection Ø 6 mm push-in connection Ø ¼" Threaded port M7
Operating voltages	24 V DC
Electrical connection at the valve	Rectangular plug
Manual override	standard
Flow rate: Q_{n_n} value Air [l/min]	Measured at +20 °C, 6 bar pressure at valve inlet and 1 bar pressure difference
Pressure values [bar]	Measured as overpressure to the atmospheric pressure
Response times [ms]	Measured according to ISO 12238

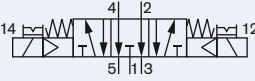
Order chart for valves

Circuit function	Orifice [mm]	Q_{n_n} value air [l/min]	Pressure range [bar]	Nominal power [W]	Response times		Article no.
					Opening [ms]	Closing [ms]	
 <p>5/2 way solenoid valve, with 2 impulse coils and manual override</p>	2.5	200	2.0-7.0	1	15	15	154183 
 <p>5/3 way solenoid valve, in middle position all ports locked, with manual override</p>	2.5	200	2.0-7.0	1	15	20	154184 
 <p>5/3 way valve, in middle position ports 2 and 4 exhausted, with manual override</p>	2.5	200	2.0-7.0	1	15	20	154185 

16.5 mm width per station Multi-way for solenoid valve Types 6526 and 6527



The solenoid valve Types 6526 and 6527 consist of a pneumatic valve body fitted with Type 6106 rocker pilot valve. The rocker principle allows switching of high pressure at low power consumption and fast response times. The pilot valves are equipped with manual override as a standard.

Specification	
Body material	PA (polyamide)
Seal material	NBR
Media	Lubricated and non-lubricated dry air, neutral gases (10 µm filter)
Port connection	Flange for MP12
Pneumatic modules	Type MP12 with G 1/8, NPT 1/8 Plug-in coupling Ø 8 mm
Manual override	Standard
Voltage	24 V DC
Nominal power	2 W, 1 W
Duty cycle	Continuous operation (100% ED)
Elec. Connection on valve	Tag connector acc. to DIN EN 175301 - 803 (previously DIN 43650) Form C
Mounting	With 2 screws M3 x 30
Installation position	As required, preferably with pilot valve upright
Flow rate: Q _{Nn} value air [l/min]	Measured at +20 °C, 6 bar pressure at valve inlet and 1 bar pressure difference
Pressure ranges [bar]	Measured as overpressure to the atmospheric pressure
Response times [ms]	Measured acc. to ISO 12238

Order chart for valves

Circuit function	Orifice [mm]	Q _{Nn} value air [l/min]	Pressure range [bar]	Nominal power [W]	Response times		Voltage/Frequency [V/Hz]	Article no.
					Opening [ms]	Closing [ms]		
C 3/2 way servo-controlled solenoid valve, normally closed, with manual override	6	700	1.0-10 ¹⁾	2	20	12	24 V DC	156842 ²⁾
			1.0-10 ¹⁾	2	20	12	24 V DC	163028 ²⁾
			2.0-10	2	20	12	24 V DC	156318 ²⁾
			2.0-10	2	20	12	24 V DC	158944 ²⁾
			2.0-8.0	1	20	17	24 V DC	156840 ²⁾
			2.0-8.0	1	20	12	24 V DC	158947 ²⁾
D 3/2 way servo-controlled solenoid valve, normally open, with manual override	6	700	1.0-10 ¹⁾	2	20	12	24 V DC	163029 ²⁾
			2.0-10	2	12	20	24 V DC	156320 ²⁾
			2.0-10	2	20	12	24 V DC	158946 ²⁾
			2.0-8.0	1	17	20	24 V DC	156841 ²⁾
H 5/2 way servo-controlled solenoid valve, pilot air and manual override	6	700	1.0-10 ¹⁾	2	20	12	24 V DC	156828 ²⁾
			1.0-10 ¹⁾	2	20	12	24 V DC	163030 ²⁾
			2.0-10	2	20	12	24 V DC	156337 ²⁾
			2.0-10	2	20	12	24 V DC	158942 ²⁾
			2.0-8.0	1	20	17	24 V DC	156827 ²⁾
			2.0-8.0	1	20	12	24 V DC	158943 ²⁾

¹⁾ version with auxiliary air

²⁾ electric connection with manual override.

³⁾ closing time approx. 5 ms higher when used together with valve unit

More valve options

Covering plates

When all the valve connections in a basic valve unit module are not used, then these connections should be covered by the appropriate covering plate for full efficiency.

Covering plates	Article no.
Covering plate for solenoid valve Type 6524/6525	650373 ²⁾
Covering plate for solenoid valve Type 6524 2 x 3/2 way valve	661092 ²⁾
Covering plate for solenoid valve Type 6526/6527	653765 ²⁾

Exhaust plates

An exhaust plate is mounted on the pneumatic module of the valve unit and offers an additional possibility to remove compressed air from the system.

Exhaust plates	Article no.
Exhaust air plate complete Type 6524/6525	655166 ²⁾
Exhaust air plate complete Type 6526/6527	653697 ²⁾

18 mm Anreihmaß Magnetventil 5470



The solenoid valve Type 5470 consist of a pneumatic valve body fitted with Type 6106 rocker pilot valve.

An armature with a tilting bearing, similar o a rocker, tilts within the body of the pilot valve, and switches the valve. The minimal tilting movement of the rocker is non-wearing, and basic lubrication is unnecessary.

The Type 5470 R is available as a 3/2 and 4/2 way valve. The valves can be mounted together individually using the module flange. In various applications, they can be used advantageously as valve blocks. Different variants are available for service ports 2 and 4.

Specification	
Orifice	DN4.0
Body material	Polyamid (PA)
Valve internal	Ultramid
Seal material	NBR
Media	Compressed air, neutral gases (5 µm-filter)
Medium temperature	-10 ... +50 °C
Ambient temperature	-10 ... +55 °C
Supply port connections 1 and 3	Module flange
Service port connections 2 and 4 (variants)	Threaded port G 1/8 Threaded port NPT 1/8 Tube connection SL 6/4 mm Push-in Ø 6 mm
Operating voltages	24 V DC, 110-120 V DC, 220-240 V DC, (for alternating current, use valves with UC-coil)
Voltage tolerance	± 10 %
Duty cycle	Continuous operation
Elec. Connection on valve	Tag connector acc. to DIN 43 650 Form C, for Cable Plug Type 1057 and Type 2506 (see accessory); Rectangular plug (5.08)
Ignition protection	EEx ia IIC T6 on request
Type of protection	IP65 (with cable plug)
Installation position	As required, preferably with pilot valve upright

Order chart for valves

Circuit function	Orifice [mm]	C _N value air [l/min]	Service ports 4 and 2	Pressure range [bar]	Nominal power [W]	Voltage/Frequency [V/Hz]	Article no. (Valve island)	Article no. (Valve block)	
	4	300	Push-in Ø 6 mm, below	2-8	1	24 V DC	132479	135203	
				2-10	2	24 V DC	133148	135204	
				2-10	3	110-120 DC		132952	
				2-10	3	220-240 DC		132953	
	4	300	Push-in Ø 6 mm, below	2-8	1	24 V DC	132481	136742	
				2-10	2	24 V DC	136741	136743	
				2-10	3	110-120 DC		136744	
				2-10	3	220-240 DC		136745	
	4	300	Push-in Ø 6 mm, front	2-8	1	24 V DC	132487	135205	
				2-10	2	24 V DC	133149	135206	
				2-10	3	110-120 DC		132954	
	4	300	Push-in Ø 6 mm, below	2-8	1	24 V DC	132489	135207	
				2-10	2	24 V DC	133150	135208	
				2-10	3	110-120 DC		132956	
	4	300	Push-in Ø 6 mm, front with throttle-check valve	2-8	1	24 V DC	132488	135209	
				2-10	2	24 V DC	133151	135210	
				2-10	3	110-120 DC		133152	
					2-10	3	220-240 DC		133153

Continued on page 9

Order chart for valves, continued

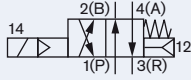
Circuit function	Orifice [mm]	Q_{Nn} value air [l/min]	Service ports 4 and 2	Pressure range [bar]	Nominal power [W]	Voltage/ Frequency [V/Hz]	Article no. (Valve island)	Article no. (Valve block)
G 	4	300	Threaded port G 1/8, front	2-8	1	24 V DC	132483	135211
				2-10	2	24 V DC	133157	135212
				2-10	3	110-120 DC		132958
				2-10	3	220-240 DC		132959
	4	300	Threaded port G 1/8, front, with throttle- check valve	2-8	1	24 V DC	132484	135213
				2-10	2	24 V DC	133159	135214
				2-10	3	110-120 DC		133160
				2-10	3	220-240 DC		133161
	4	300	Tube connec- tion SL6/4 mm, front	2-8	1	24 V DC	133162	135215
				2-10	2	24 V DC	133163	135216
				2-10	3	110-120 DC		133164
				2-10	3	220-240 DC		133166

¹⁾ In operation of alternating current (AC), place a cable plug Type 2506 with rectifier upstream.

Composition valve block & valve island

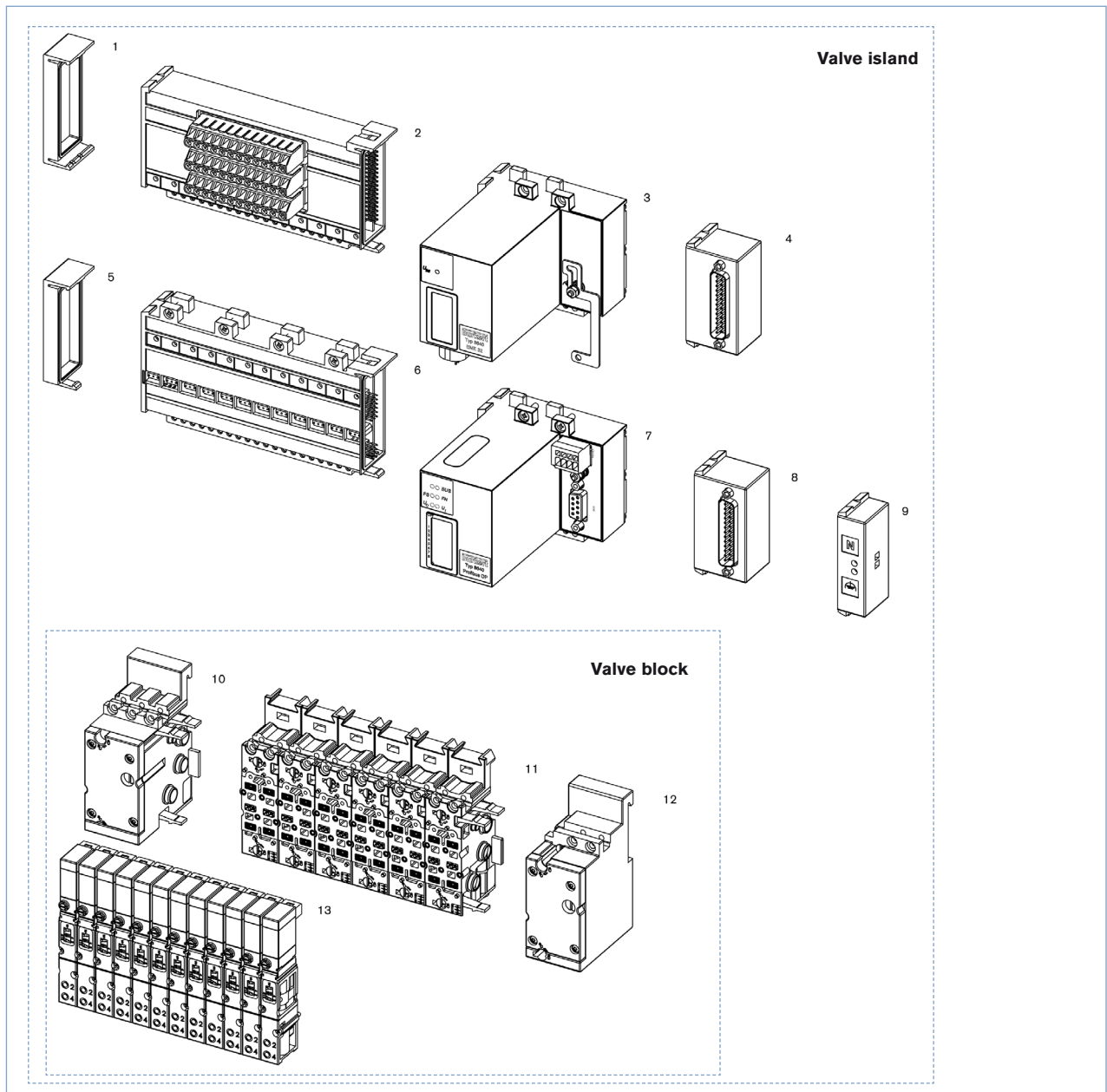

Basic module choice, for further modules see the following pages

- | | |
|--|--|
| 1. Electrical end module left | 2. Terminal module for electronic inputs |
| 3. Extension module for electrical inputs | 4. Multipin repeater inputs (initiators) |
| 5. Electrical end module left | 6. Basic electrical module standard |
| 7. Fieldbus module | 8. Multipin valve outputs |
| 9. Common connection module | 10. Pneumatic connection module left, Type MP11 |
| 11. Basic pneumatic modules, Type MP11 for 12 valves | 12. Pneumatic connection module right, Type MP11 |
| 13. Valves of Type 6525 (5/2 way) | |

Module description

Collective line- and multipol-modules
for single connection of valves and feedback

 0460/6524/6525 width/station 11 mm	 6526/6527 width/station 16.5 mm	 5470 width/station 18 mm
---	--	---

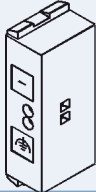

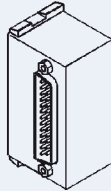
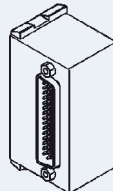

Connection via individual stranded wires

- Looped-through ground potential
- Max. 24 valves
- IP20 degree of protection
- Screw terminal

<p>Multipin module Valve outputs</p> 	<p>Multipin module Repeater inputs (initiators)</p> 
---	---

Fieldbus modules

 0460/6524/6525 width/station 11 mm	 6526/6527 width/station 16.5 mm	 5470 width/station 18 mm
--	---	--

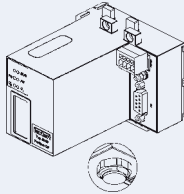

Fieldbus PROFIBUS-DP, IP20 degree of protection

- Max. 24 valves
- Max. 32 repeaters (in connection with EME module)
- Transmission rates 9.6; 19.2; 93.75; 187.5; 500 kBaud; 1.5; 3; 6; 12 MBaud
- Power supply with rectangular plug (4 pin male)
- Bus connection D-SUB (9 pin female)
- With RIO-connection M8 (4 pin)

Internal bus extension RIO-VA module, IP20 degree of protection

- Max. 24 valves
- Max. 32 repeaters (in connection with EME module)
- Plug connection
- RIO cable for bus extension 1 m (Article no. 917 498)
2 m (Article no. 917 999)

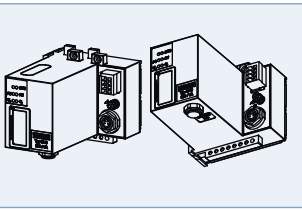

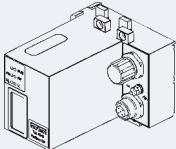



Fieldbus PROFIBUS-DP IP54 degree of protection
on connection with the basic electrical module the complete system meets the degree of protection IP54

- Max. 24 valves
- Max. 32 repeaters (in connection with EME module)
- Transmission rates 9.6; 19.2; 93.75; 187.5; 500 kBaud; 1.5; 3; 6; 12 MBaud
- Power supply with M12 circular plug (4 pin male)
- Bus connection M12 (5 pin female)
- For a trouble-free assembly use the following Y-piece (Article no. 902 098)

Module description

Fieldbus modules

		
0460/6524/6525 width/station 11 mm	6526/6527 width/station 16.5 mm	5470 width/station 18 mm

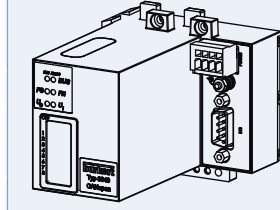

Fieldbus CANopen, IP20 degree of protection

Max. 24 valves,
Max. 32 repeaters (in connection with EME module)
Transmission rates 20, 125, 250 or 500 kBaud
Power supply with rectangular plug (4 pin)
Bus connection D-SUB (9 pin male)

Fieldbus CANopen, IP54 degree of protection on connection with the basic electrical module the complete system meets the degree of protection IP54

Max. 24 valves
Max. 32 repeaters (in connection with EME module)
Transmission rates 20, 125, 250 or 500 kBaud
Power supply with M12 circular plug (4 pin male)
Bus connection M12 (5 pin male)
For a trouble-free assembly use the following Y-piece (Article no. 788 643)

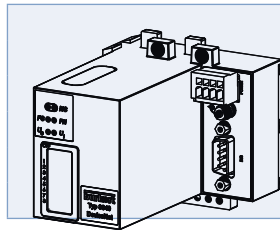
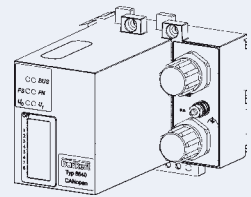

Fieldbus Device Net, IP20 degree of protection

Max. 24 valves
Max. 32 repeaters (in connection with EME module)
Transmission rates 125, 250 or 500 kBaud
Power supply with rectangular plug (4 pin)
Bus connection D-Sub (9 pin male)

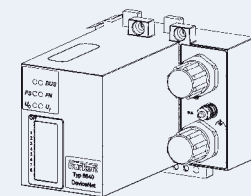

Fieldbus Device Net, IP54 degree of protection on connection with the basic electrical module the complete system meets the degree of protection IP54

Max. 24 valve
Max. 32 repeaters (in connection with EME module)
Transmission rates 125, 250 or 500 kBaud
Power supply with M12 circular plug (4 pin male)
Bus connection M12 (5 pin male)
For a trouble-free assembly use the following Y-piece (Article no. 788 643)



Module description

Fieldbus modules

 0460/6524/6525 width/station 11 mm	 6526/6527 width/station 16.5 mm	 5470 width/station 18 mm
---	--	---

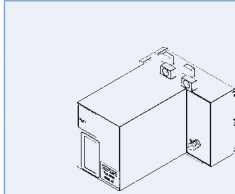

EME module (extension module inputs), IP54 degree of protection

Module for connection of repeater inputs
in connection with fieldbus modules

Fieldbus Profinet IO, Ethernet I/P, Modbus TCP Protection class IP20

Max. 24 valves

Max. 32 repeaters (in connection with EME-module)

Transmission rates 10/100 MBits/s with auto crossover

Power supply with rectangular plug (4 pin)

Bus connection RJ45 (2x)

RIO-connection M8 (4 pin)

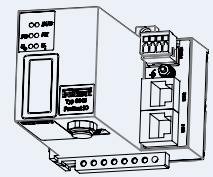

Further electrical accessories

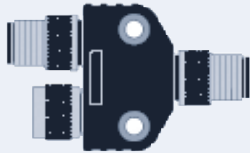

Bus Y-piece for PROFIBUS

You must use one pre-assembled plug and one plug for free assembly.
(Article no. 902098 )

(Article no. 788643 ) **Bus Y-piece for CANopen and DeviceNet**

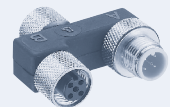

AirLINE Quick

With AirLINE Quick you can reduce the amount of the components in the control cabinet considerably. With the AirLINE Quick Adapter the valve island is directly adapted on the control cabinet floor or wall.

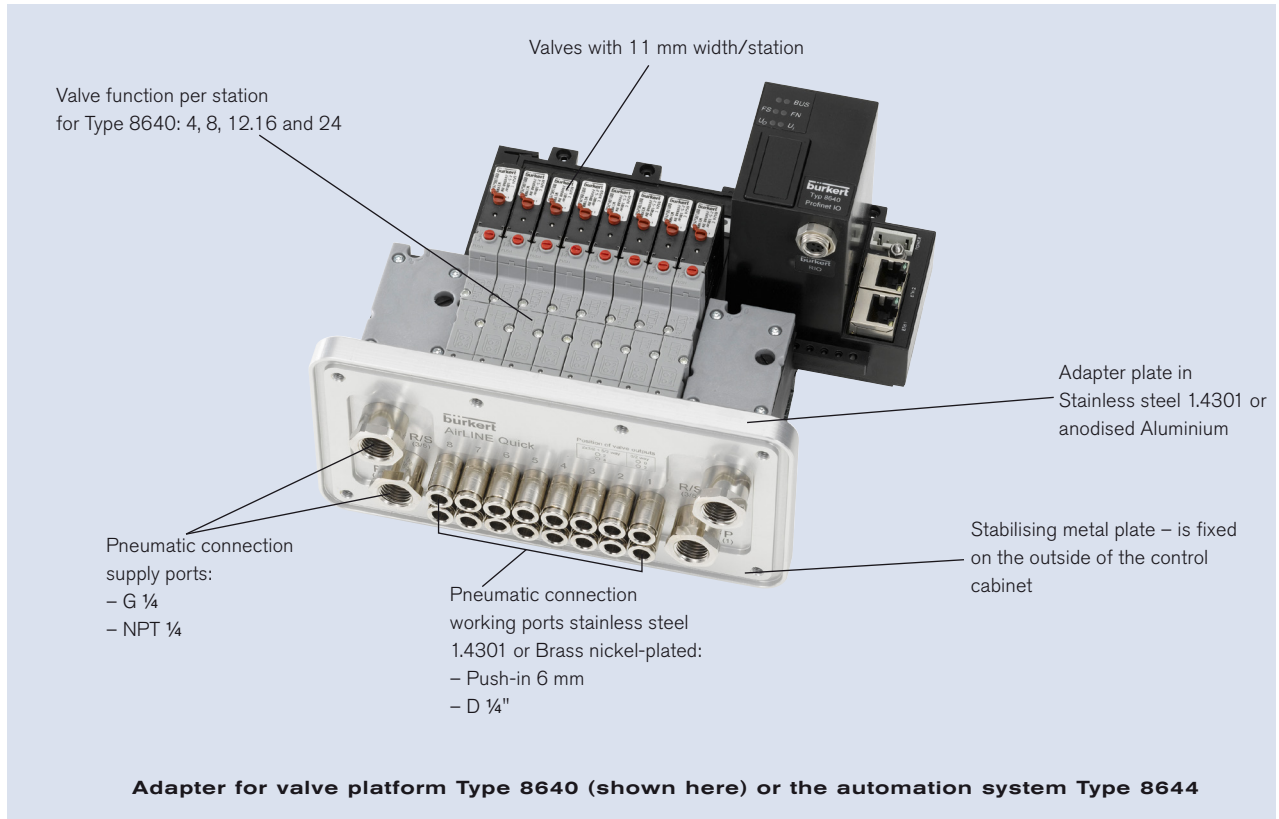

* Valves of Type 0460 cannot be installed with AirLINE Quick because of the size.

Technical data

Technical data	
Material for AirLINE Quick Adapter	Stainless steel 1.4301 anodised Aluminium
Material Pneumatic connection	Stainless steel 1.4301 Brass nickel-plated
Pneumatic connection, supply ports	G 1/4, NPT 1/4
Pneumatic connection working ports	Push-in D6 mm, D1/4"
Installation	Control cabinet wall Control cabinet floor
Valve function per station	4, 8, 12, 16 and 24

Additional accessories for AirLINE Quick

Blanking plate

A blanking plate is used to cover an existing flange for AirLINE Quick on the cabinet wall or on the cabinet floor.

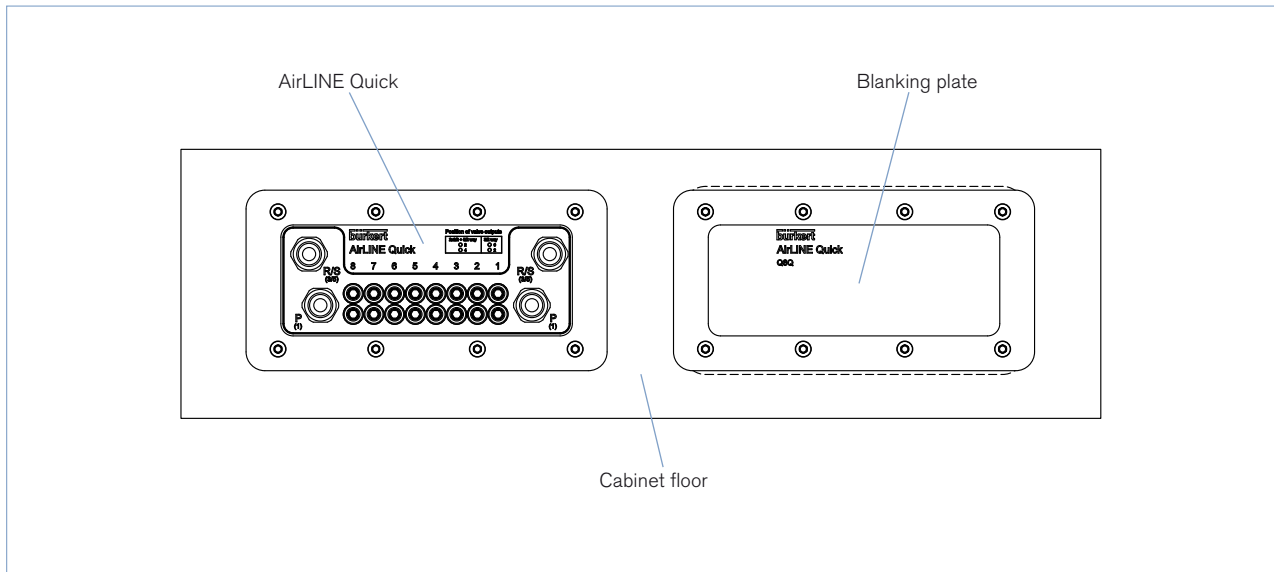

Order chart blanking plate

Material	Amount of valve slots	Article no.
Aluminium anodised	4	246937
	8	246933
	12	246929
	16	246925
Stainless steel 1.4301	4	246938
	8	246934
	12	246930
	16	246926

To find your nearest Bürkert facility, click on the orange box →

www.buerkert.com

In case of special application conditions, please consult for advice.

Subject to alteration
© Christian Bürkert GmbH & Co. KG

1803/11_EUen_00891940