

INLINE flowmeter - high temperature for continuous control



- Fluid temperature max. 125°C
Fluid pressure max. 40 bars
- 3-wire frequency pulse version
- Mounting and dismounting of the electronics by a quarter-turn
- Connection to Bürkert devices in remote versions

Type 8030-HT can be combined with...



Type 8619

Multifunction transmitter/controller



Type 8802-GD

TopControl System



Type 8611

Universal Controller eControl



Type 8032

Flow controller

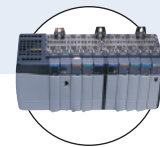

PLC

The HT paddle-wheel flowmeter for continuous flow measurement is especially designed for use in neutral, slightly aggressive, solid free liquids.

The 8030-HT is made up of a compact fitting and an electronic module quickly and easily connected together by a Quarter-Turn. The Bürkert designed stainless steel fitting system ensures simple installation of the sensors into all stainless steel pipes from DN06 to DN50.

The flowmeter produces a frequency pulse signal, proportional to the flow rate, which can easily be transmitted and processed by a Bürkert remote transmitter/controller.

General data	
Compatibility	with fittings S030-HT (see page 5)
Materials	PPS, glass fibre reinforced PA
Housing, cover	
Cable plug	
Wetted parts materials	
Fitting, sensor armature	Stainless steel
Paddle-wheel / Axis	Stainless steel / Ceramics
Bearing / Seal	Iglidur® / FKM (EPDM on request)
Electrical connection	Cable plug EN 175301-803
Connection cable	0.14 to 1.5 mm ² cross section; max. 50 m length, shielded (up to 500 m depending on installation conditions)
Complete device data (fitting + electronic module)	
Pipe diameter	DN06 to DN50 (DN65 on request)
Measuring range	0.5 to 10 m/s
Medium temperature	-15 to 125°C
Fluid pressure max.	PN40 (-15 to 90°C temperature range) PN25 (90 to 125°C temperature range)
Viscosity / Pollution	300 cSt. max. / max. 1% (Size of particles 0.5 mm max.)
Accuracy	
Teach-In	±1% of F.S.* (at 10 m/s) ¹⁾
Standard K-factor	±(1% of F.S.* + 3% o. Reading) ¹⁾
Linearity	±0.5% of F.S.* (at 10 m/s) ¹⁾
Repeatability	±0.4% of Reading ¹⁾
Environment	
Ambient temperature	-15 to +80°C (operating and storage)
Relative humidity	≤ 80%, without condensation

* F.S. = Full scale (10 m/s)

¹⁾ Under reference conditions i.e. measuring fluid = water, ambient and water temperature = 20°C, applying the minimum inlet and outlet pipe straights, matched inside pipe dimensions.

Electrical data	
Operating voltage	12 - 36 V DC, filtered and regulated
Current consumption	≤ 10 mA (no load)
Output: Frequency Transistor	NPN/PNP, open collector, max. 700 mA, NPN output: 0.2 - 30 V DC; PNP output: operating voltage
Frequency	Transistor NPN, open collector, 0... 250 Hz
Reversed polarity of DC	Protected
Standards, directives and approvals	
Protection class	IP65 with connector plugged-in and tightened
Standard	
EMC	EN 50081-1, 61000-6-2
Low voltage	EN 61010-1
Pressure	Complying with article 3 of §3 from 97/23/CE directive.*
Vibration	EN 60068-2-6
Shock	EN 60068-2-27

* For the 97/23/CE pressure directive, the device can only be used under following conditions (depend on max. pressure, pipe diameter and fluid).

Type of fluid	Conditions
Fluid group 1, §1.3.a	DN ≤ 25 only
Fluid group 2, §1.3.a	DN ≤ 32 or DN > 32 and PN*DN ≤ 1000
Fluid group 1, §1.3.b	PN*DN ≤ 2000
Fluid group 2, §1.3.b	DN ≤ 200

Design and principle of operation



The flowmeter 8030-HT is built up with an electronic module SE30-HT associated to a fitting S030-HT with integrated measurement paddle-wheel. This connection is made by means of a Quarter-Turn.

When liquid flows through the pipe, the paddle-wheel is set in rotation. The non-wetted permanent magnets inserted in the paddle wheel generate a measuring signal which frequency is proportional to the flow velocity. A conversion coefficient (K factor, available in the instruction manual of the fitting), specific to each pipe (size and material) enables the conversion of this frequency into flow rate.

The electronic module with frequency output is available with one pulse output (either NPN or PNP transistor output depending on wiring). An external power supply of 12-30 V DC is required. It is designed for connection to any system with open collector NPN or PNP frequency input. In a 3-wire system, the signal can be displayed or processed directly. The output signal is provided via cable plug according to EN 175301-803.

Installation

Minimum straight upstream and downstream distances must be observed. According to the pipe's design, necessary distances can be bigger or use a flow conditioner to obtain the best accuracy. For more information, please refer to EN ISO 5167-1.

EN ISO 5167-1 prescribes the straight inlet and outlet distances that must be complied with when installing fittings in pipelines in order to achieve calm flow conditions. The most important layouts that could lead to turbulence in the flow are shown below, together with the associated prescribed minimum inlet and outlet distances. These ensure calm, problem-free measurement conditions at the measurement point.

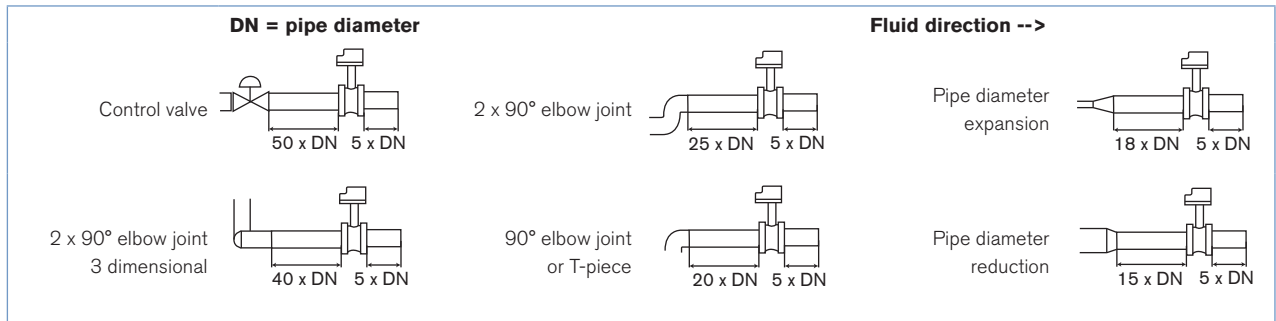

Installation (continued)

The device can be installed into either horizontal or vertical pipes.

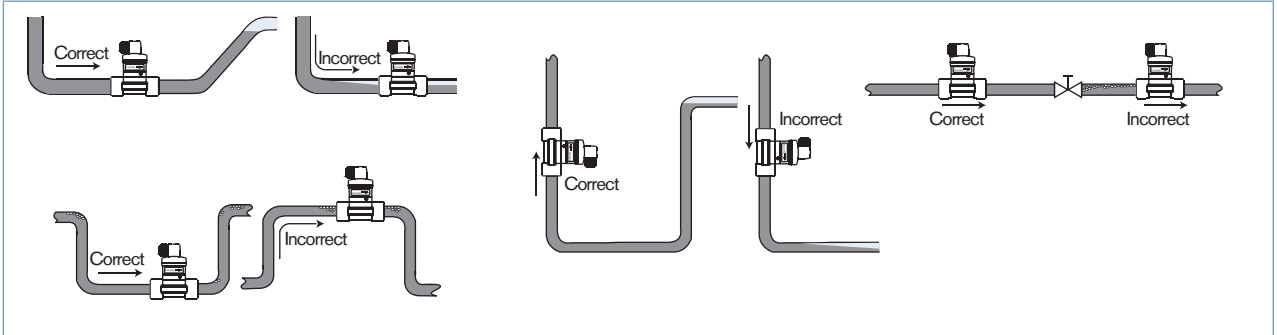

Pressure and temperature ratings must be respected according to the selected fitting material.
 The suitable pipe size is selected using the diagram Flow/Velocity/DN.
 The measuring device is not designed for gas flow measurement.

Diagram Flow/Velocity/DN

Example:

- Flow: 10 m³/h
 - Ideal flow velocity: 2...3 m/s
- For these specifications, the diagram indicates a pipe size of DN40 [or DN50 for (*) mentioned fittings]

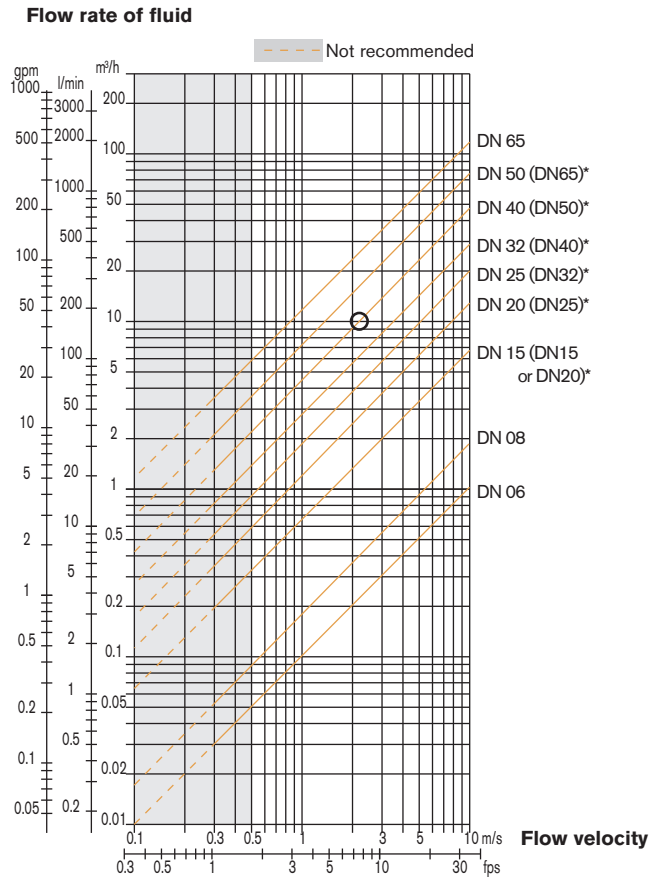

* for following fittings with:
 - external threads acc. to SMS 1145
 - weld ends acc. to SMS 3008, BS 4825 / ASME BPE or DIN 11850 Series 2
 - Clamp acc. to SMS 3017 / ISO 2852, BS 4825 / ASME BPE or DIN 32676

Dimensions

Electronic module SE30-HT

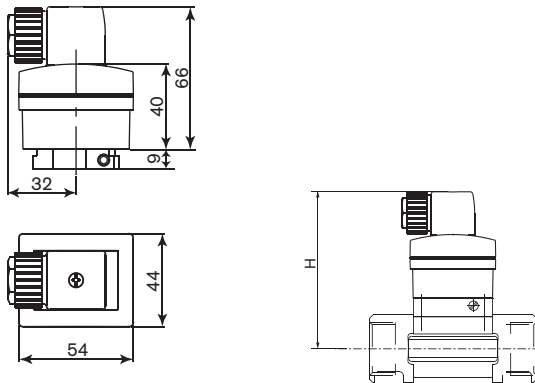

DN [mm]	H [mm]
06	95.5
08	95.5
15	100.5
20	98.0
25	98.0
32	102.0
40	105.5
50	112.0

Fitting S030-HT with

- internal threaded port connection (DN15-DN50)

in stainless steel (316L - 1.4404)

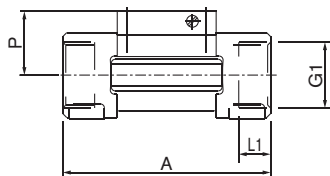

- external threaded port connection (DN06 and DN08)

in stainless steel (316L - 1.4404)

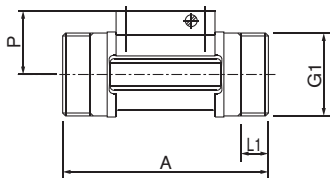

DN [mm]	P [mm]	A [mm]	G1 [inch]	L1 [mm]
06	29.5	90.0	G 1/4	14.0
08	29.5	90.0	G 1/2 NPT 1/2 Rc 1/2	14.0 14.0 14.0
15	34.5	84.0	G 1/2 NPT 1/2 Rc 1/2	16.0 17.0 15.0
20	32.0	94.0	G 3/4 NPT 3/4 Rc 3/4	17.0 18.3 16.3
25	32.2	104.0	G 1 NPT 1 Rc 1	23.5 18.0 18.0
32	35.8	119.0	G 1 1/4 NPT 1 1/4 Rc 1 1/4	23.5 21.0 21.0
40	39.6	129.0	G 1 1/2 NPT 1 1/2 Rc 1 1/2	23.5 20.0 19.0
50	45.7	148.5	G 2 NPT 2 Rc 2	27.5 24.0 24.0

Fitting S030-HT with
weld-end connection

in stainless steel (316L - 1.4404)

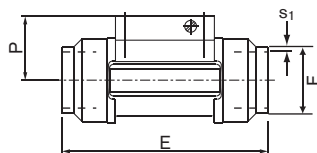

DN [mm]	P [mm]	E [mm]	F [mm]	S ₁ [mm]
15	34.5	84.0	21.3	1.6
20	32.0	94.0	26.9	1.6
25	32.2	104.0	33.7	2.0
32	35.8	119.0	42.4	2.0
40	39.6	129.0	48.3	2.0
50	45.7	148.5	60.3	2.0

Ordering chart for flowmeter Type 8030-HT

The flowmeter Type 8030-HT is built-up of an electronic module Type SE30-HT + an INLINE fitting Type S030-HT

Electronic module Type SE30-HT - for fitting Type S030-HT

Description	Voltage supply	Output	Electrical connection	Item no.
Pulse version	12-36 V DC	Frequency with pulse PNP or NPN, open collector	Cable plug EN 175301-803	449 694



Two versions of the fitting in DN15 and DN20 exist, having different K factors. Only version 2, identified by the "v2" marking, is available from March 2012.

The "v2" marking can be found on the side of the DN15 or DN20 fitting in metal



Fitting Type S030-HT

Description	Item no. DN06*	Item no. DN08**	Item no. DN15	Item no. DN20	Item no. DN25	Item no. DN32	Item no. DN40	Item no. DN50
G-port connection, internal thread	552 735	449 725	449 726	449 727	449 728	449 729	449 730	449 731
Weld-end connection (EN ISO 1127/ ISO 4200)	-	-	551 757	551 758	551 759	551 760	551 761	551 762
RC-port connection, internal thread (ASEAN)	-	449 739	449 740	449 741	449 742	449 743	449 744	449 745
NPT-port connection, internal thread (NAFTA)	-	449 732	449 733	449 734	449 735	449 736	449 737	449 738

* Only version with G external thread 1/4"

** Only version with G/NPT/RC external thread 1/2"

Ordering chart - accessories for fitting S030-HT (to be ordered separately)

Specifications		Item no.
O-Ring set	FKM (DN06 to DN50)	426 340
	EPDM (DN06 to DN50)	426 341
Sensor armatures in stainless steel	Stainless steel paddle wheel, FKM seal, screws for DN15 (except DN15 v2 and DN20 v2) to DN50	551 764
	Stainless steel paddle wheel, FKM seal, screws for DN06, DN08, DN15 v2 and DN20 v2	449 723
	Stainless steel paddle wheel, EPDM seal, screws for DN15 (except DN15 v2 and DN20 v2) to DN50	551 763
	Stainless steel paddle wheel, EPDM seal, screws for DN06, DN08, DN15 v2 and DN20 v2	449 724

Interconnection possibilities with the sensor Type 8030-HT

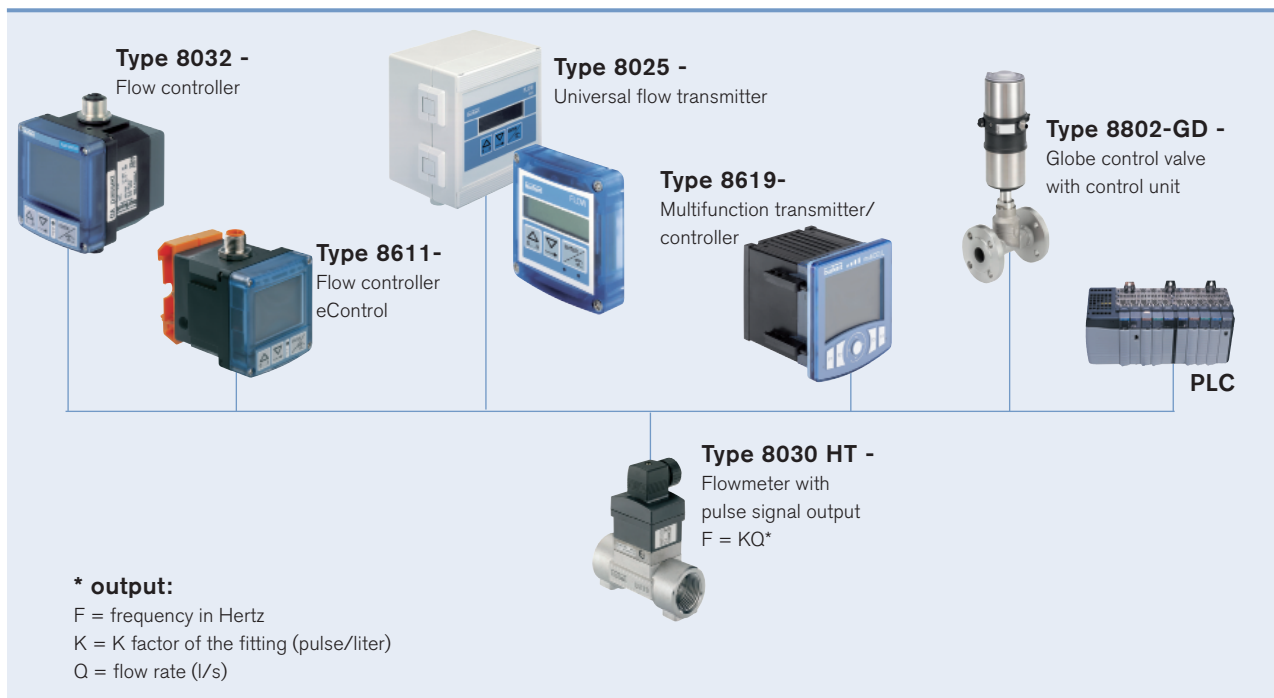

For more details about Bürkert remote devices, please refer to corresponding data sheets.

To find your nearest Bürkert facility, click on the orange box →

www.burkert.com

In case of special application conditions,
please consult for advice.

Subject to alteration.
© Christian Bürkert GmbH & Co. KG

1206/12_EU-en_00891889