

Mass Flow Controller (MFC)/ Mass Flow Meter (MFM) for Gases

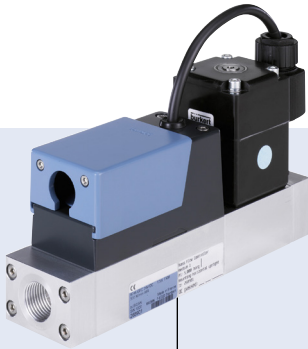

Type 8746 can be combined with...

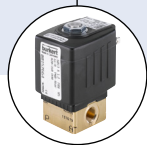

Type 6013
2/2- way
Solenoid valve



Type 6027
2/2- way
Plunger valve



Type 0330
2/2- or 3/2 way
Solenoid valve



Type 0290
2/2 way
Diaphragm valve



Type ME43
Fieldbus Gateway



The mass flow controller / meter Type 8746 for gases is intended for the use in a bus or CANopen network. The bus network technology is based on CAN physics and was developed by Bürkert especially for Industrial Ethernet or fieldbus communication in applications with multiple control loops. In combination with the system control unit (SCU) Type ME2X, the CANopen based communication can be translated to the customer's fieldbus. The mass flow controller (MFC) / meter (MFM) can always be switched between bus and CANopen communication. Given that, Type 8746 can also be directly integrated into existing CANopen networks.

Type 8746 can be configured as MFM or MFC. Optional, four different gases can be calibrated.

The thermal inline sensor is located directly in the main gas stream and therefore reaches very fast response times. A direct-acting proportional valve as regulating unit guarantees high sensitivity. The integrated PI controller ensures outstanding control characteristics of the MFC / MFM. Type 8746 is especially designed for use in harsh environments due to a low sensitivity to contamination, high protection class and explosion-proof.

MFC Type 8746 is available in two versions: With electromagnetic or with motor-driven proportional valve.

- Nominal flow ranges from 20 I_N /min up to 2500 I_N /min
- High accuracy and repeatability
- Communication via fieldbus based on CANopen
- Optional: ATEX II Cat. 3G/D
- Electromagnetic and motor-driven valve actuation available

General technical data		
Operating medium	Neutral, non-contaminated gases, others on request	
Calibration medium	Operating gas or air with correction function	
Medium temperature	-10 °C ¹⁾ to +70 °C (-10 °C ¹⁾ to +60 °C with oxygen)	
Ambient temperature	-10 °C to +50 °C (higher temperatures on request)	
Materials	Body Housing Seals	
	Stainless steel or aluminium Aluminium diecasting (coated) FKM or EPDM (depending on gas) ²⁾	
Port connection	G 1/4", 3/8", 1/2", 3/4", 1", NPT 1/4", 3/8", 1/2", 3/4", 1" Sub-base	
Electr. connection	M12 plug, 5 pin	
Operating voltage	24 V DC	
Voltage tolerance	±10 %	
Residual ripple	±2 %	
Digital Comm.	CANopen or CAN based bus	
Configuration memory (included in delivery)	EEPROM (µSIM card: bus relevant data and information about spec. control loop in order to ease replacement)	
Input-/ Output signals	none, communication via bus	
Installation	horizontal or vertical	
Nom. flow ranges of typical gases (Other gases on request)		
Gas	Min. Q_{nom} [I_N /min]	Max. Q_{nom} [I_N /min]
Acetylene	20	975
Ammonia	8	1000
Argon	20	1600
Carbon dioxide	20	800
Air	20	2500
Methane	20	400
Propane	20	400
Oxygen	20	2500
Nitrogen	20	2500

¹⁾ When using a motor valve the minimum medium temperature is 0 °C.

²⁾ When using a motor valve additionally:

- Type 3280 DN4: Seat seal in PEEK

- Type 3285: Seat seal in Al₂O₃

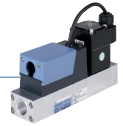

Technical data: Type 8746 with electromagnetic proportional valve

Type 8746 can be configured as MFM or MFC. For MFCs the direct-acting proportional valves of Types 287x are used. These electromagnetic proportional valves are normally closed and stand for highest accuracy and repeatability with settling / response times of few hundred milliseconds.

Technical data	
Nominal flow range (Q_{nom})	20 ... 1500 I_N /min (N_2), MFM up to 2500 I_N /min (N_2)
Turn-down ratio	50:1 ³⁾
Max. operating pressure Data in overpressure to atmospheric pressure	10 bar (with MFCs the max. pressure depends on the orifice of the valve) optional up to 25 bar for MFM
Accuracy	±1.5 % o.R. ±0.3 % F.S. (after 15 min. warm up time)
Repeatability	±0.1 % F.S.
Settling (MFC)/ Response (MFM) time ($t_{95\%}$)	<500 ms
Proportional valve (electromagnetic) Valve orifice range k_{vs} value range	normally closed 0.8 ... 12 mm 0.02 ... 2.5 m^3/h
Power consumption⁴⁾	Max. 2 W (as MFM) Max. 10.5 ... 29.5 W (as MFC, depending on valve type)
Protection class	IP65 and IP67
ATEX compliance (optional)	II 3G Ex nA IIC T* Gc X and II 3D Ex tc IIIC T***C Dc X ⁵⁾
Dimensions	See pages 5-8
Total weight	ca. 1.8 kg (Al, 16 W-valve), ca. 3.1 kg (VA, 16 W-valve)
Device status	RGB-LED based on NAMUR NE107

³⁾ With vertical installation and flow downwards the turn-down ratio is 1:10

⁴⁾ Referring to the typical power consumption (at 23 °C ambient temperature, nominal flow and 30 mins regular operation) The data according to UL 61010-1 may differ (see manual)

⁵⁾ Acc. to DIN EN 60079-0 and DIN EN 60079-15, T3/4 and T160 °C/135 °C depending on the device version

Technical data: Type 8746 with motor-driven proportional valve



The Type 8746 with motor-driven valves is especially designed for applications with high inlet pressures up to 22 bars or high flow rates (at a low pressure drop). The motor's power consumption to hold a specific opening position is nearly zero. This key feature can reduce the energy consumption of a plant dramatically. Without electrical power the valve remains in its current position. The maximum duty cycle of the motor depends on the ambient temperature. The duty cycle does not refer to the duty cycle of the device but to the duty cycle of the motor. The motor is not switched on unless the valve is to move. Frequent set-point value changes will drastically increase the duty cycle of the motor.

Derating curve for Type 8746 with motor valve

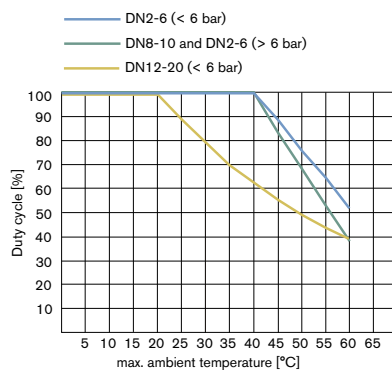

Technical data	
Nominal flow range (Q_{nom})	20 up to 2500 I_N /min (N_2)
Turn-down ratio	50:1 ⁶⁾
Max. operating pressure Data in overpressure to atmospheric pressure	22 bar (with MFCs the max. pressure depends on the orifice of the valve)
Accuracy	±2 % o.R. ±0.5 % F.S. (after 15 min. warm up time)
Repeatability	±0.5 % F.S.
Settling time ($t_{95\%}$)	<5 sec.
Proportional valve (motor-driven) Valve orifice range k_{vs} value range	normally persisting 2 ... 20 mm 0.5 ... 7.8 m^3/h
Power consumption	Max. 2 W (as MFM) Max. 10 ... 14 W (as MFC) ⁷⁾
Protection class	IP50 (higher protection class on request)
Dimensions	See pages 9-10
Total weight	ca. 1.67 kg (Al, standard, valve 3280), ca. 2.94 kg (VA, standard, valve 3280)
Device status⁸⁾	at MFM: RGB-LED based on NAMUR NE107 at valve: RGB-LED displaying the valve opening

⁶⁾ With vertical installation and flow downwards the turn-down ratio is 1:10

⁷⁾ Data during moving of the valve. The power to hold a specific valve opening <1 W

⁸⁾ Detailed description of the LED colors: see manual

Features to fulfil the ATEX requirements

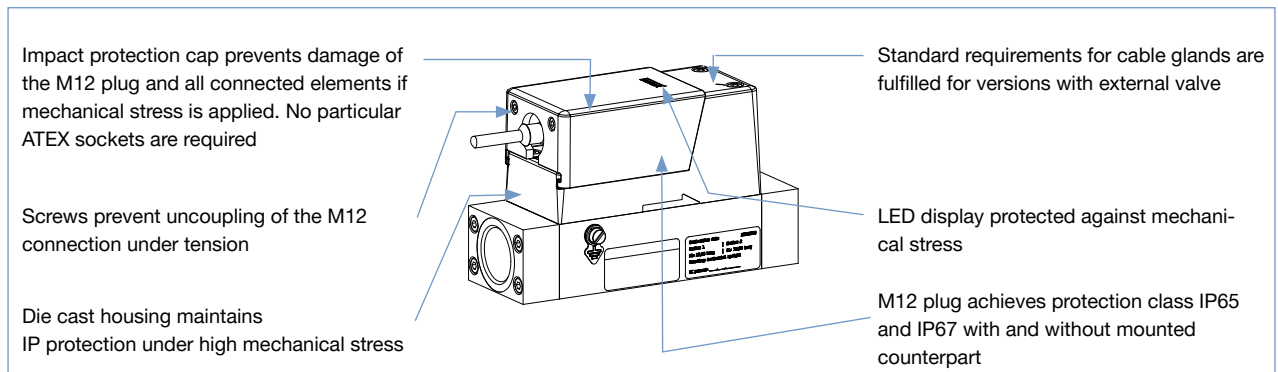

Pin Configuration

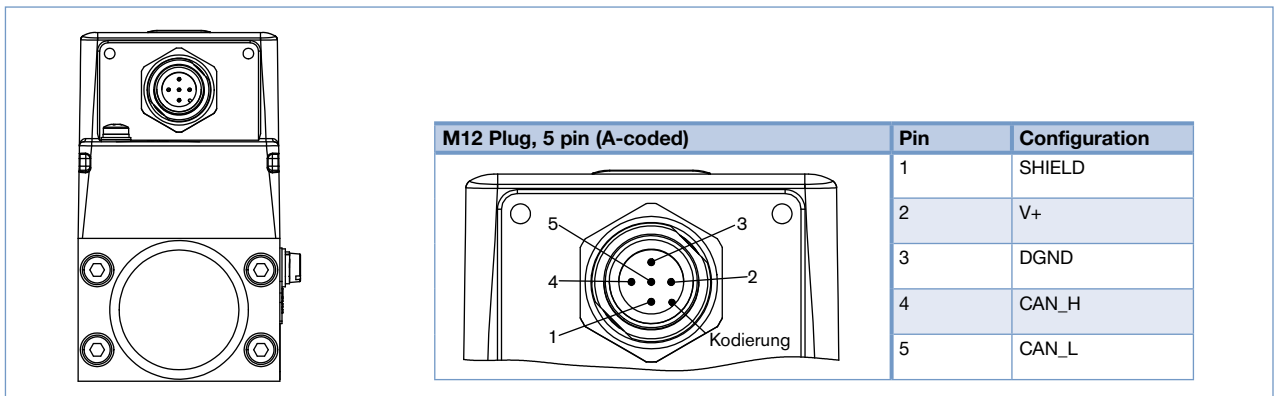

Pressure Loss Diagram of a MFM (ref. to air)

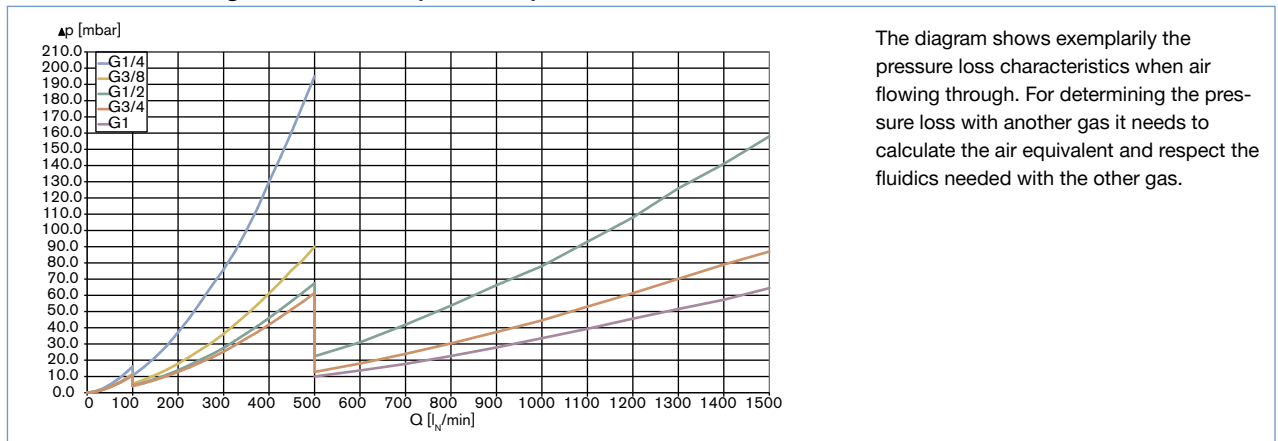

Notes Regarding the Configuration

For the proper choice of the actuator orifice within the MFC, not only the required maximum flow rate Q_{nom} , but also the pressure values directly before and after the MFC (p_1 , p_2) at this flow rate Q_{nom} should be known.

In general, these pressures are not the same as the overall inlet and outlet pressures of the whole plant, because usually there are additional flow resistors (tubing, additional shut-off valves, nozzles etc.) present both before and after the controller. Please use the request for quotation form on p. 12 to indicate the pressures directly before

and after the MFC. If these should be unknown or not accessible to a measurement, estimates are to be made by taking into account the approximate pressure drops over the flow resistors before and after the MFC, respectively, at a flow rate of Q_{nom} . In addition, please quote the maximum inlet pressure p_{1max} to be encountered. This data is needed to make sure the actuator is able to provide a close-tight function within all the specified modes of operation.

► The request form on page 12 contains the relevant fluid specification. Using the experience of Bürkert engineers already in the design phase provide us with a copy of the request containing the necessary data together with your inquiry or order.

Measuring Principle

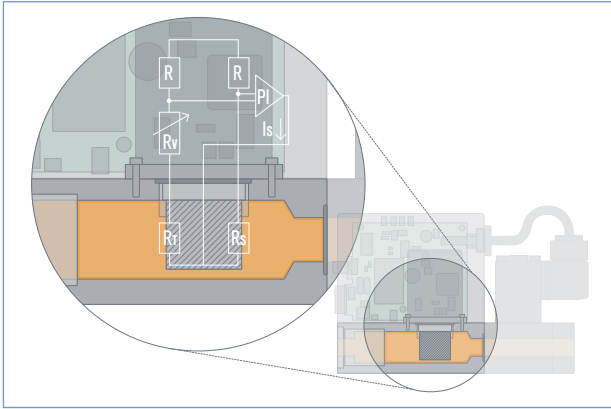

This sensor works as a hot-film anemometer in the so-called CTA operational mode (Constant Temperature Anemometer). To do this, two resistors with precisely specified temperature coefficients located directly in the media flow and three resistors located outside the flow are connected together to form a bridge.

The first resistor in the gas flow (R_1) measures the fluid temperature, while the second, low-value resistor (R_2) is heated so that it is maintained at a fixed, predefined over-temperature with respect to the fluid temperature. The heating current required to maintain this is a measure of the heat being removed by the flowing gas, and represents the primary measurement.

An adequate flow conditioning within the MFC and the calibration with high-quality flow standards ensure that the mass of gas flowing per time unit can be derived from the primary signal with high accuracy.

Software Bürkert Communicator



To install the software, click on the download button.

Part of Bürkert's new EDIP program (Efficient Device Integration Platform) is the Bürkert Communicator. This software can be run under MS-Windows and it is available on Bürkert's website for free. The Bürkert Communicator allows convenient system configuration and parameterization of all connected field devices. An accessory part, the büS stick – please see ordering chart for accessories – serves as the interface between computer and process instruments. It transfers "USB data" to "CAN data".

The Communicator allows:

- Diagnosis - Parameterization - Registration and storage of process data. The Communicator allows:
- Diagnosis
- Parameterization
- Registration and storage of process data
- Data logging
- To watch graph of process
- To update firmware of the büS device connected
- To program system controls by User-f(x) – e.g. gas blending
- guided re-calibration
- ...

Dimensions [mm] Type 8746

MFC with valve Type 2873 (9 W-coil)

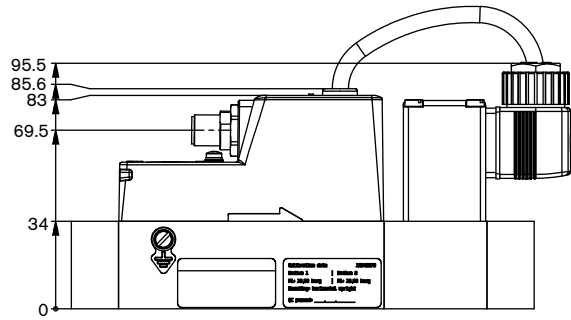
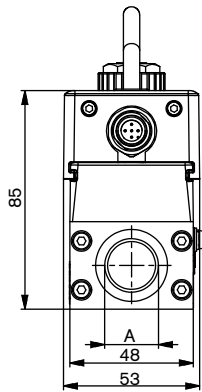
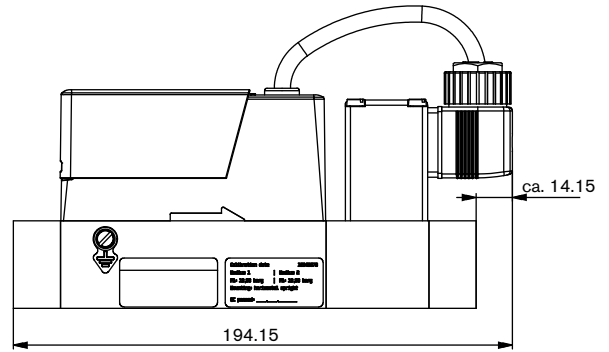
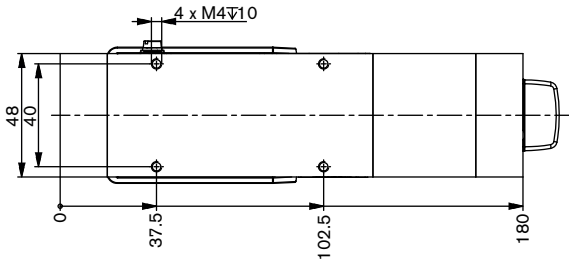

A
G ¼; NPT ¼
G ⅜; NPT ⅜
G ½; NPT ½
G ¾; NPT ¾

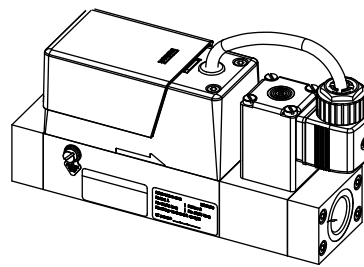

Dimensions [mm] Type 8746

MFC with valve Type 2875 (16 W-coil)

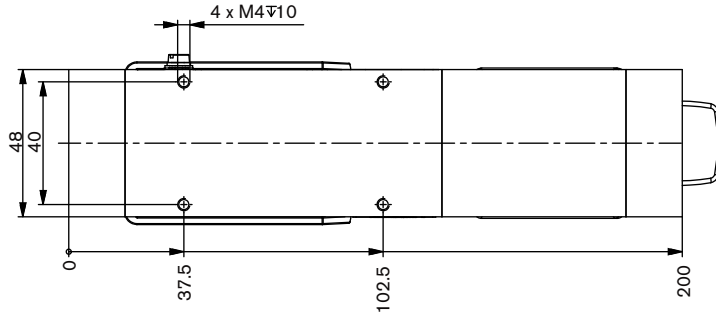

Version with standard base block

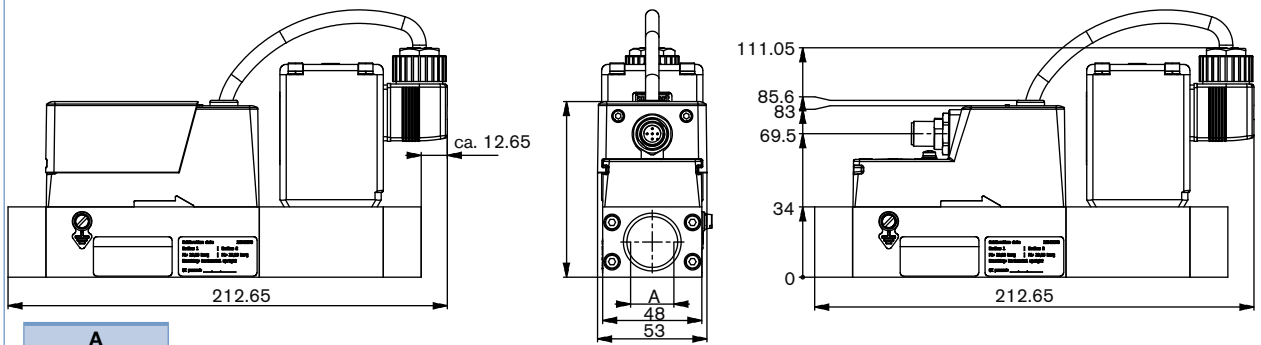

A
G ¼; NPT ¼
G ⅜; NPT ⅜
G ½; NPT ½
G ¾; NPT ¾

Dimensions [mm] Type 8746

MFC with valve Type 2836 (24 W-coil)

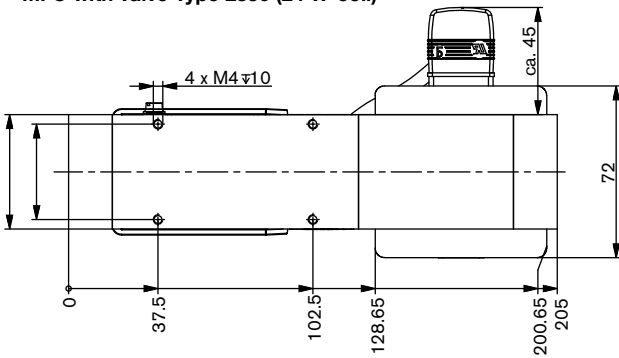

Version with standard base block

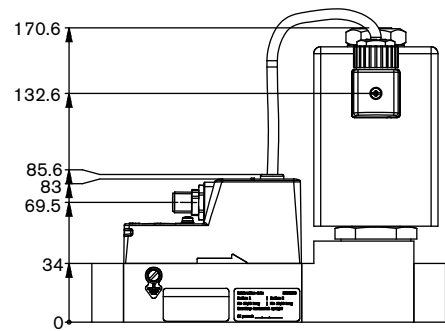
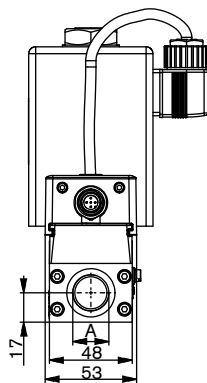
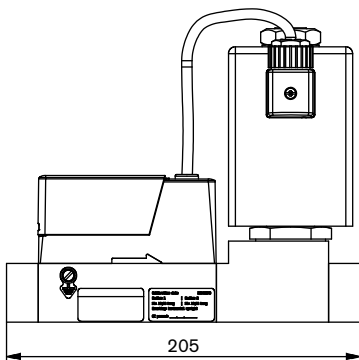

A
G ¼; NPT ¼
G ⅜; NPT ⅜
G ½; NPT ½
G ¾; NPT ¾

Version with base block for large nominal flow rates

For a nominal flow $Q_{nom} > 1500 \text{ l}_N/\text{min}$ the overall length increases by 30 mm

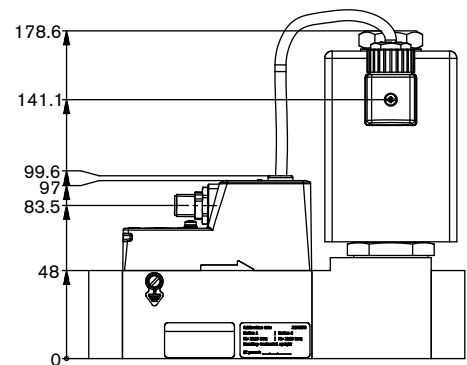
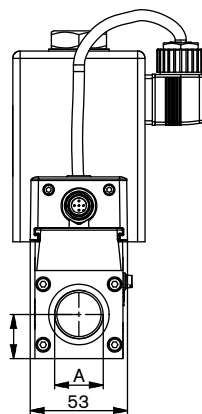
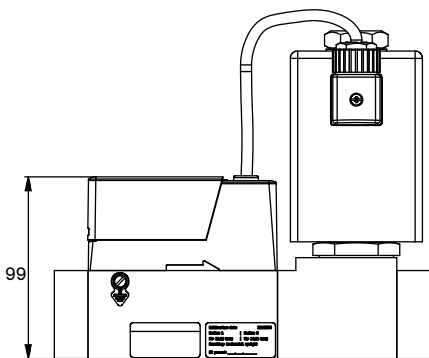

A
G ½; NPT ½
G ¾; NPT ¾
G 1; NPT 1

Dimensions [mm] Type 8746

MFM version

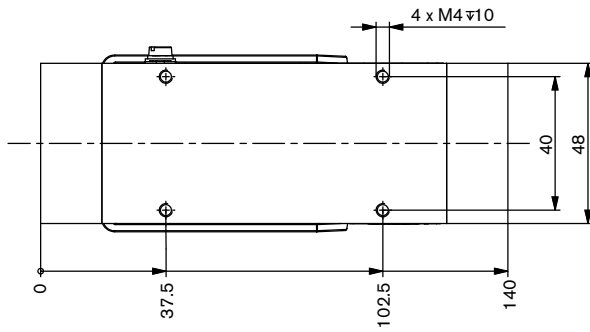

Version with standard base block

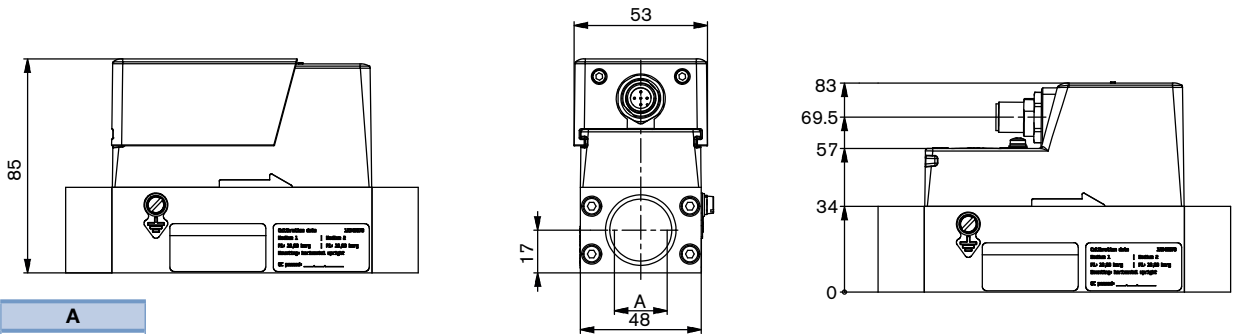

A
G ¼; NPT ¼
G ¾; NPT ¾
G ½; NPT ½
G ¾; NPT ¾

Version with base block for large nominal flow rates

For a nominal flow $Q_{nom} > 1500 \text{ l}_N/\text{min}$ the overall length increases by 30 mm

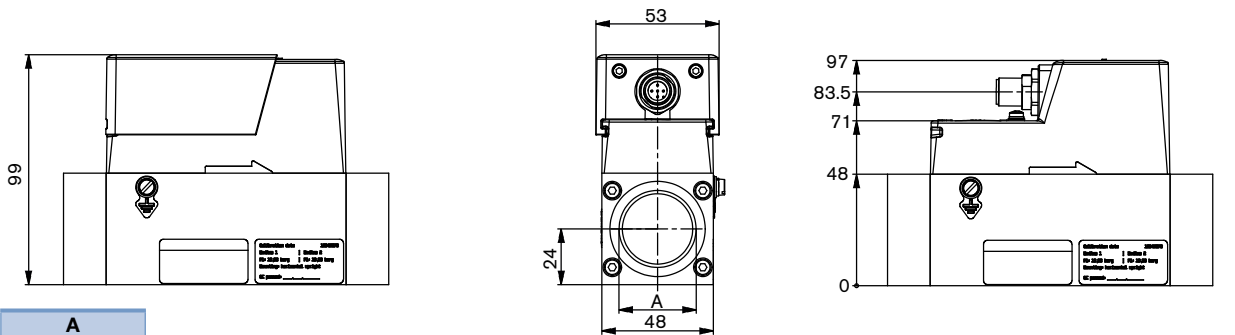

A
G ½; NPT ½
G ¾; NPT ¾
G 1; NPT 1

Dimensions [mm] Type 8746

MFC with valve Type 3280

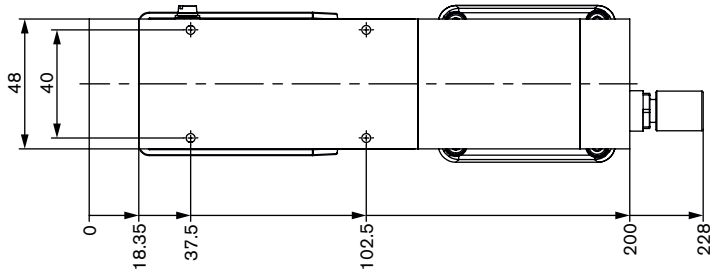

Version with standard base block

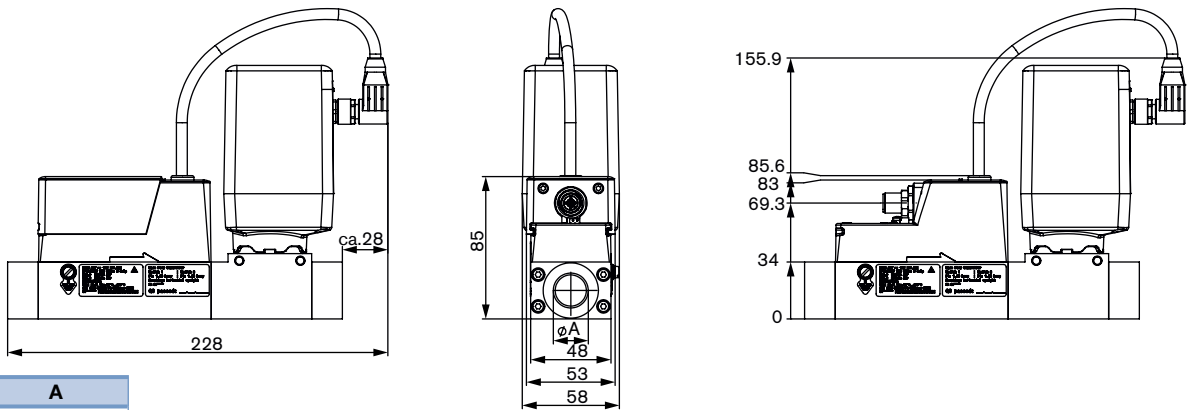

A
G ¼; NPT ¼
G ⅜; NPT ⅜
G ½; NPT ½
G ¾; NPT ¾

Version with base block for large nominal flow rates

For a nominal flow $Q_{nom} > 1500 \text{ l}_N/\text{min}$ the overall length increases by 30 mm

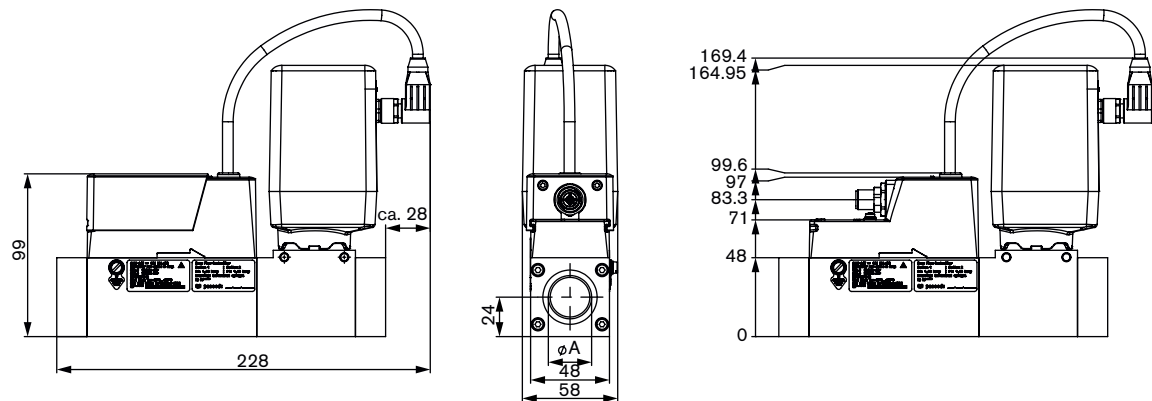

A
G ½; NPT ½
G ¾; NPT ¾
G 1; NPT 1

Dimensions [mm] Type 8746

MFC with valve Type 3285
Valve orifice DN12 and DN15

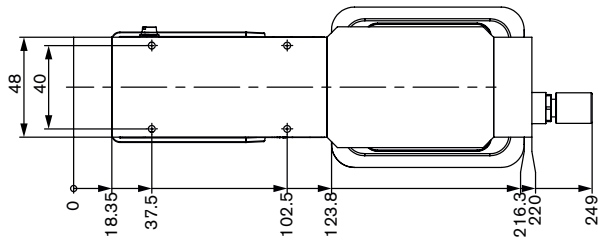

Valve orifice DN20 and DN25

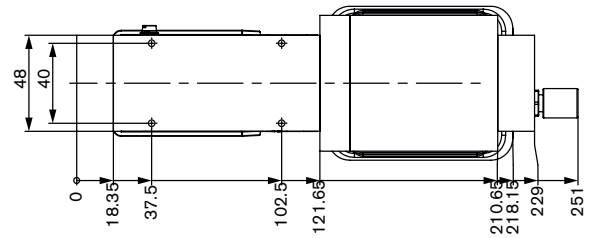

Version with base block for large nominal flow rates: Valve orifice DN12 and DN15
For a nominal flow $Q_{nom} > 1500 \text{ l}_N/\text{min}$ the overall length increases by 30 mm

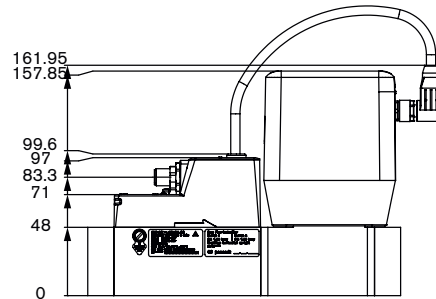
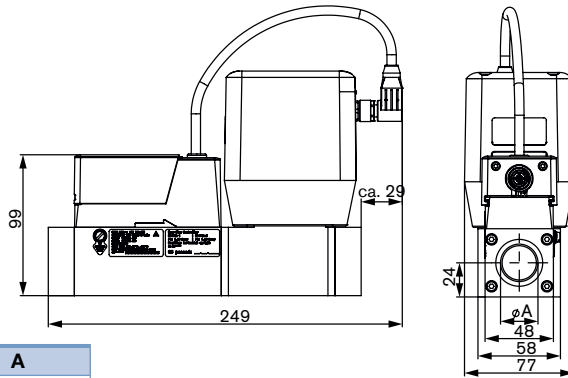





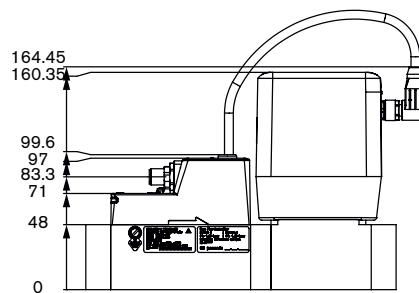
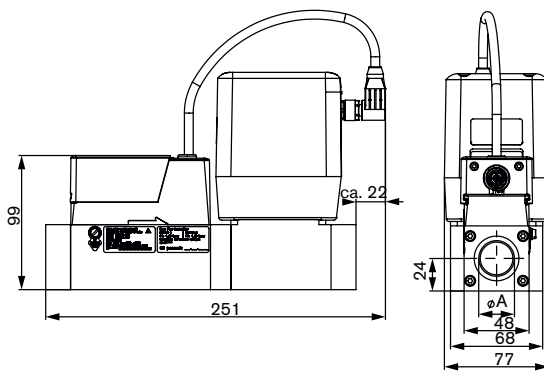













A
G 1/2; NPT 1/2
G 3/4; NPT 3/4
G 1; NPT 1

Version with base block for large nominal flow rates: Valve orifice DN20 and DN25
For a nominal flow $Q_{nom} > 1500 \text{ l}_N/\text{min}$ the overall length increases by 30 mm



A
G 1/2; NPT 1/2
G 3/4; NPT 3/4
G 1; NPT 1

Ordering Chart for Accessories

Article	Article no.
büS cable extension M12 0.1 m	772492 
büS cable extension M12 0.2 m	772402 
büS cable extension M12 0.5 m	772403 
büS cable extension M12 1 m	772404 
büS cable extension M12 3 m	772405 
Connector M12, female, straight ⁹⁾	772416 
Connector M12, male, straight ⁹⁾	772417 
Connector M12, female, angled ⁹⁾	772418 
Connector M12, male, angled ⁹⁾	772419 
Power supply Type 1573 for rail mounting, 100 ... 240 V AC/ 24 V DC, 1.25 A, NEC Class 2 (UL 1310)	772438 
Power supply Type 1573 for rail mounting, 100 ... 240 V AC/ 24 V DC, 1 A, NEC Class 2 (UL 1310)	772361 
Power supply Type 1573 for rail mounting, 100 ... 240 V AC/ 24 V DC, 2 A, NEC Class 2 (UL 1310)	772362 
Power supply Type 1573 for rail mounting, 100 ... 240 V AC/ 24 V DC, 4 A	772363 
Y junction	772420 
Y junction for connecting two separately powered segments of a büS network	772421 
Termination resistor 120 Ohm M12 male	772424 
Termination resistor 120 Ohm M12 female	772425 
büS-Stick Set 1 ((incl. cable (M12)), stick with integrated termination resistor, power supply and software)	772426 
büS-Stick Set 2 (incl. cable (M12)), stick with integrated termination resistor)	772551 
SIM card	on request
LabVIEW device driver	on request
EDS-File (CANopen)	Download from www.burkert.com
Software Bürkert Communicator	Download from www.burkert.com

⁹⁾ It is possible that the M12 connectors cannot be used together on the same side of a Y-junction. If that is the case, please use a prefabricated cable which uses typically a thinner connector.

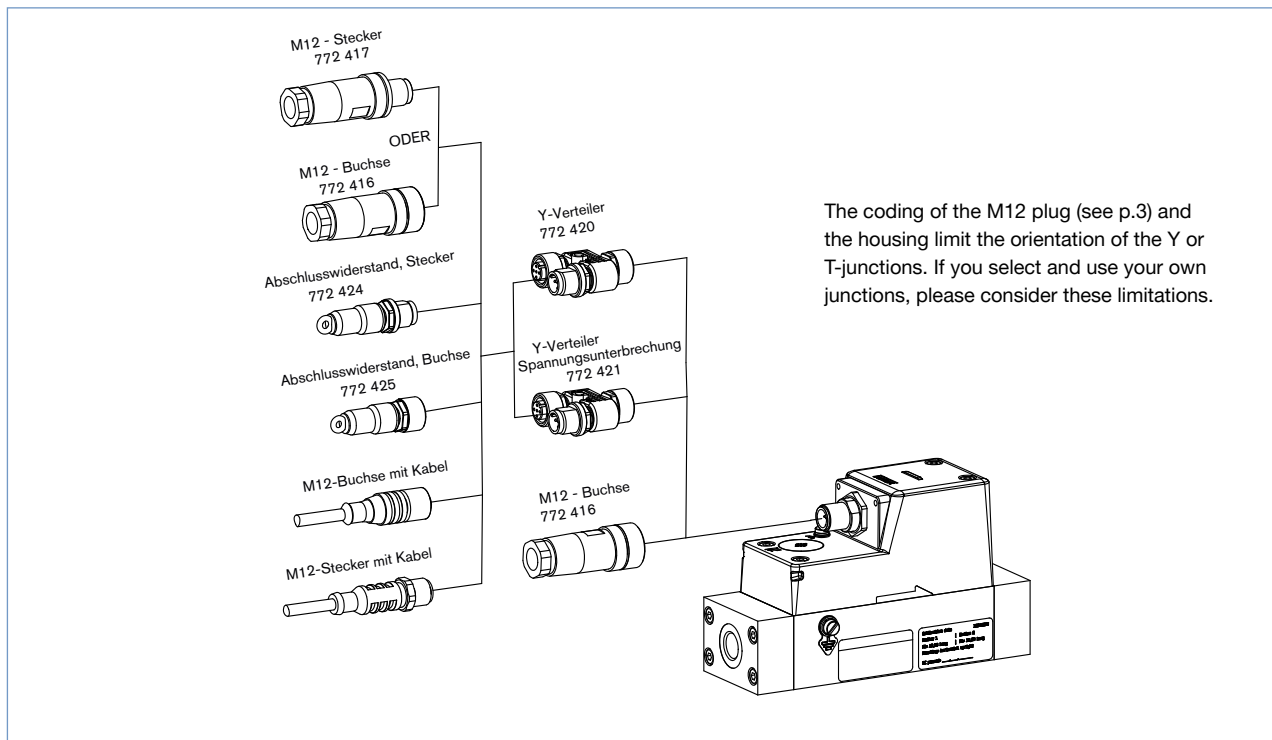

MFC/MFM-applications - Request for quotation

▶ Please complete and send to your nearest Bürkert sales centre

Company	Contact person
Customer No	Department
Address	Tel./Fax
Postcode/Town	E-mail

MFC-Application MFM-Application Quantity Required delivery date

ATEX compliance

Preferred valve type: electromagnetic (highly dynamic) motor-driven (energy saving)

Medium data

Type of gas (or gas proportion in mixtures)

Density kg/m³ ¹⁰⁾

Gas temperature [°C or °F] °C °F

Moisture content g/m³

Abrasive components/solid particles no yes, as follows:

Fluidic data

Flow range Q_{nom}

Min. l_N/min ¹⁰⁾ l_S/min (slpm) ¹¹⁾

Max. m_N³/h ¹⁰⁾ kg/h

cm_N³/min ¹⁰⁾ cm_S³/min (sccm) ¹¹⁾

l_N/h ¹⁰⁾ l_S/h ¹¹⁾

Inlet pressure at Q_{nom} ¹³⁾ $p_1 =$ bar(ü) ●

Outlet pressure at Q_{nom} $p_2 =$ bar(ü) ●

Max. inlet pressure P_{1max} bar(ü) ●

MFC/MFM port connection

without screw-in fitting

¼" G-thread (DIN ISO 228/1) ¼" NPT-thread (ANSI B1.2)

⅜" G-thread (DIN ISO 228/1) ⅜" NPT-thread (ANSI B1.2)

½" G-thread (DIN ISO 228/1) ½" NPT-thread (ANSI B1.2)

¾" G-thread (DIN ISO 228/1) ¾" NPT-thread (ANSI B1.2)

1" G-thread (DIN ISO 228/1) 1" NPT-thread (ANSI B1.2)

with screw-in fitting (acc. to specification for pipeline)

mm Pipeline (external Ø)

inch Pipeline (external Ø)

Sub-base

Installation

horizontal

vertical, flow upwards vertical, flow downwards

Ambient temperature °C

Material data

Body base Aluminium Stainless steel

Seal FKM EPDM

Electrical data

Signals for set point and actual valve CANopen or bÜS

● Please quote all pressure values as overpressures with respect to atmospheric pressure [bar(ü)]

¹⁰⁾ at: 1.013 bar(a) and 0 °C

¹¹⁾ at: 1.013 bar(a) and 20 °C

¹³⁾ matches with calibration pressure

To find your nearest Bürkert facility, click on the orange box →

www.burkert.com

In case of special application conditions, please consult for advice.

Subject to alteration.
© Christian Bürkert GmbH & Co. KG

1806/10_EU-en_00895280