

## Flowmeter for gases

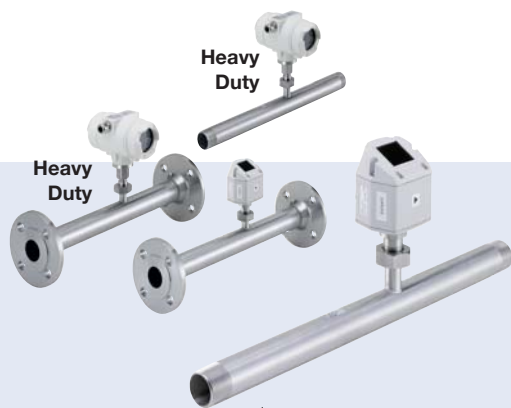

- Thermal mass flow measurement
- Integrated inlet and outlet pipes for flow conditioning
- Pipe sizes up to 2"
- Integrated display
- Standard and Heavy Duty version available

Type 8008 can be combined with...

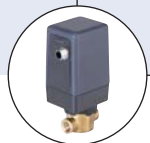

**Type 3280**  
Proportional valve



**Type 3285**  
Proportional valve



**Type 8611**  
eCONTROL



**Type 8802**  
ELEMENT



**Type BUPLUS**

This flowmeter series is made for measuring of especially large flow rates and uses the calorimetric measuring principle. A heated sensor element is cooled down by the gas flow. This cooling effect which depends on the flow velocity and the gas characteristics is the measure for the mass flow rate. This kind of mass flow measurement is independent of pressure and temperature. The flowmeter can be used for monitoring air supplies, but also qualifies for measuring other gases like nitrogen, oxygen, carbon dioxide, natural gas, methane, argon and hydrogen.

The display can be rotated by 180°. Further there is a totaliser integrated which counts the gas volume flowing through the pipe. It can be reset by the console. The flowmeter's pressure drop is negligibly low, the measurement works without any moving parts.

In combination with a solenoid control valve or an air operated process control valve decentralized flow control loops up to DN50 are possible.

Type 8008 is available in two versions:

- Standard
- Heavy Duty (with a robust aluminium die casting electronics housing).

In the Heavy Duty version the sensor is encapsulated in stainless steel.

Technical data	
<b>Full scale ranges (<math>Q_{nom}</math>)<sup>1)</sup></b>	Up to 825 Nm <sup>3</sup> /h (air)
<b>Operating gases</b>	Air, nitrogen, oxygen, natural gas, methane, argon, nitrous oxide, carbon dioxide, helium (hydrogen on request)
<b>Max. operating pressure</b>	Up to 16 bar; optional up to PN 40 (Standard) Up to 50 bar (Heavy Duty)
<b>Calibration gas</b>	Air, zero point adjustment with operating gas; with hydrogen and helium: calibration with operating gas
<b>Gas temperature</b>	-30 bis +80 °C (higher temperatures on request)
<b>Ambient temperature</b>	-30 bis +80 °C (higher temperatures on request)
<b>Accuracy</b>	± 1.5 % o. R. <sup>2)</sup> ± 0.3 % F.S. <sup>3)</sup> (based on air and in consideration of the inlet and outlet sections)
<b>Span</b>	1:50
<b>Body material</b>	Stainless steel 1.4301 (standard), Stainless steel 1.4571 (heavy duty)
<b>Electronics housing material</b>	Polycarbonate (standard), Aluminium die casting (heavy duty)
<b>Sealing material</b>	NBR, FKM (for oxygen)
<b>Pipe connection</b>	R1/2", R3/4", R1", R1 1/4", R1 1/2", R2" (all connections as external thread) acc. to DIN EN 10226 (ISO 7-1) or flange connections acc. to DIN EN 1092-1 (stainless steel 1.4404), other connections on request
<b>Electrical connection</b>	see page 3-4
<b>Power supply</b>	18 - 36 V DC, 5 W
<b>Output signal (actual value output)</b>	4 - 20 mA
<b>Max. load (current output)</b>	< 500 Ω
<b>Digital output</b>	RS 485 interface, Modbus-RTU
<b>Protection class</b>	IP65
<b>Dimensions [mm]</b>	see drawings on pages 4-5
<b>Pulse output</b>	1 pulse per m <sup>3</sup>
<b>Options</b>	- Oxygen conformity declaration - Cleaned, free of oil and fat

<sup>1)</sup> for 1.013 bar(ü) and 0 °C (acc. to DIN 1343)

<sup>2)</sup> o.R.: of reading

<sup>3)</sup> F.S.: full scale (full scale values see page 2: "Flow range" table)

## Ordering chart for air with operating pressure of 6 barg - standard version

Pipe connection	Inner diameter of pipe	Flow range	Overall length	Item no.
R 1/2"	16.1 mm	up to 80 Nm <sup>3</sup> /h <sup>4)</sup>	300 mm	773 501
R 3/4"	21.7 mm	up to 160 Nm <sup>3</sup> /h <sup>4)</sup>	475 mm	773 502
R 1"	27.3 mm	up to 270 Nm <sup>3</sup> /h <sup>4)</sup>	475 mm	773 503
R 1 1/4"	36.0 mm	up to 490 Nm <sup>3</sup> /h <sup>4)</sup>	475 mm	773 504
R 1 1/2"	41.8 mm	up to 670 Nm <sup>3</sup> /h <sup>4)</sup>	475 mm	773 505
R 2"	53.1 mm	up to 1100 Nm <sup>3</sup> /h <sup>4)</sup>	475 mm	773 506

<sup>4)</sup> Index N: Standard condition, flow rate referred to 0 °C and 1.013 bar(a)  
Calibration for another flow range, other gases and/or operating pressure on request.

### Note:

The total length of the device is not enough to condition the flow. Please refer to the design notes.

## Flow Ranges

	1/2"	3/4"	1"	1 1/4"	1 1/2"	2"
	[m <sup>3</sup> /h]	[m <sup>3</sup> /h]	[m <sup>3</sup> /h]	[m <sup>3</sup> /h]	[m <sup>3</sup> /h]	[m <sup>3</sup> /h]
<b>Ref. to DIN 1945/ ISO 1217: 20 °C and 1000 mbar:</b>						
Air	90	170	290	530	730	1195
<b>Ref. to DIN 1343: 0 °C and 1013 mbar:</b>						
Air	80	160	270	490	670	1100
Argon	Ar 140	275	460	830	1140	1870
Carbon dioxide	CO <sub>2</sub> 90	175	290	525	720	1185
Nitrogen	N <sub>2</sub> 80	155	260	470	650	1060
Oxygen	O <sub>2</sub> 85	165	280	505	695	1140
Natural gas, methane	NG 50	105	170	310	430	705

Item no. for a flowmeter calibrated on other gases like air and other flow ranges on request, see specification sheet on page 5.

## Installation

DN = pipe diameter

Flow direction ►

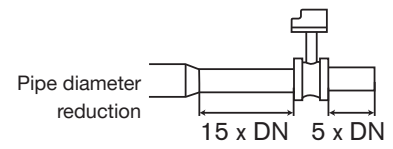
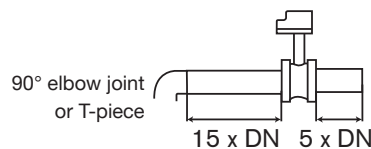
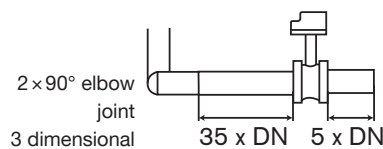
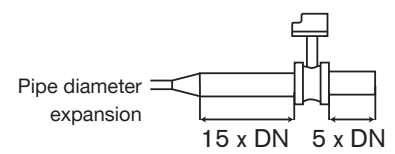
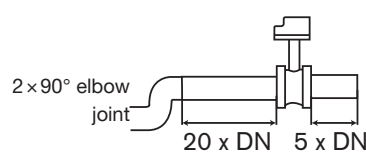
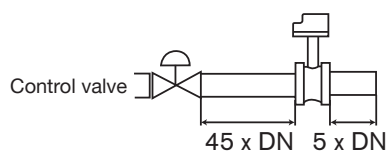

## Pin Assignment - standard version

**Attention:** The Pin assignment was changed with the new device generation. For questions, please contact the responsible Bürkert facility.

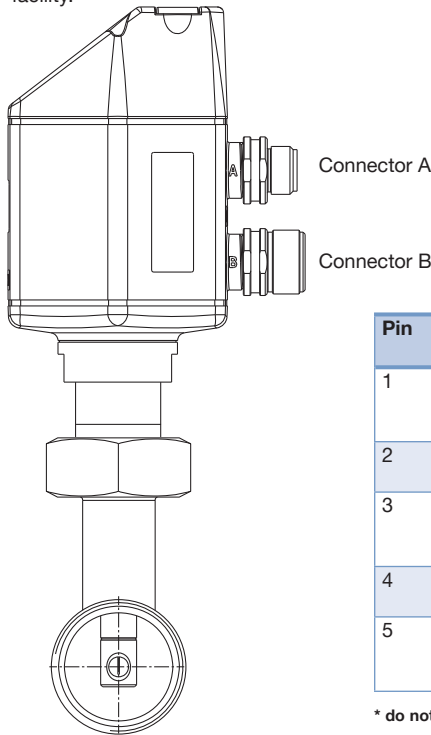

M12 connector

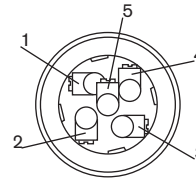

Pin	Connector A (connection port)	Connection cable A	Connector B (pulse port)	Connection cable B
1	<b>VB +</b> Positive voltage supply 12–36 V DC	br	*	br
2	<b>RS 485 (A)</b> Modbus-RTU A	wh	<b>GND</b>	wh
3	<b>VB -</b> Negative voltage supply 12–36 V DC	bl	<b>DIR</b> Direction input	bl
4	<b>RS 485 (B)</b> Modbus-RTU b	sw	<b>P</b> Pulse for usage	sw
5	<b>I+</b> Current signal 4–20 mA, selected measurement signal	gr	<b>P</b> Pulse for usage	gr

\* do not connect, just for internal use. Do not connect with an electrical potential and/or ground.

M12 connector A

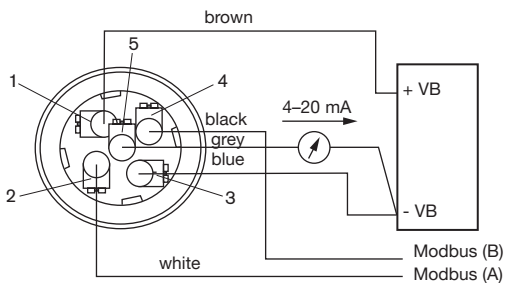

M12 connector B

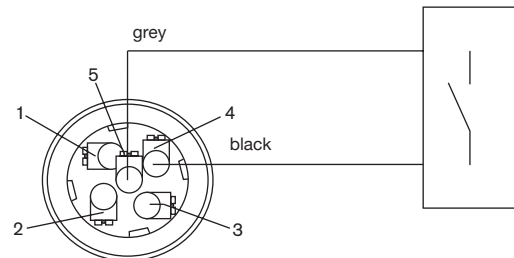
**Note:**

If the sensor is placed at the end of the Modbus system a termination is required. The sensors have an internal switchable termination. To use that the 6 fastening screws from the lid must be released and the internal DIP Switch must be set to "On". Please ensure that the connection plugs are still plugged and the gasket is installed correctly. Alternatively, a 120R resistor can be installed in the plug between pin 2 and pin 4.

## Ordering Chart for Accessories - standard version

Item	Item no.
5 m cable, with 5 pin M12 plug at one end	770 217
10 m cable, with 5 pin M12 plug at one end	770 795
Power supply Type 1573 for rail mounting, 100–240 V AC/ 24 V DC, 1.25 A, NEC Class 2 (UL 1310)	772 438
Power supply Type 1573 for rail mounting, 100–240 V AC/ 24 V DC, 1 A, NEC Class 2 (UL 1310)	772 361
Power supply Type 1573 for rail mounting, 100–240 V AC/ 24 V DC, 2 A, NEC Class 2 (UL 1310)	772 362
Power supply Type 1573 for rail mounting, 100–240 V AC/ 24 V DC, 4 A	772 363

Without ordering cables, the flowmeter comes with M12-connector for port A.

## Pin assignment - heavy duty version

## Electrical connection

## Plug layout

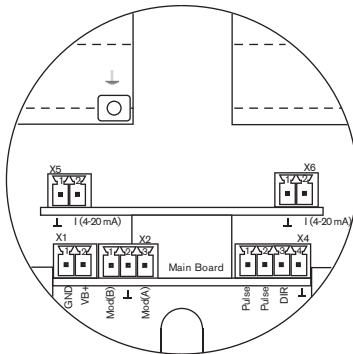

## Voltage supply

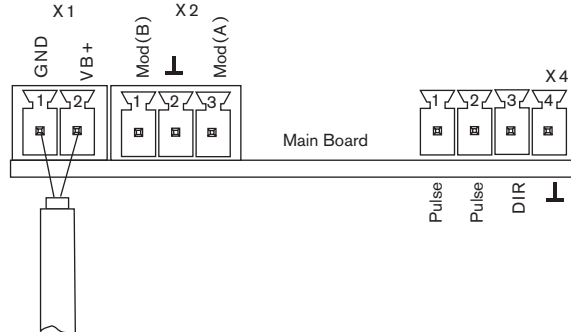

Plug	Pin	Description
X1 Voltage supply	1	VB- (negative voltage supply GND)
	2	VB+ (positive voltage supply 12V – 36 V DC)
X2 Modbus	1	Modbus (B)
	2	Modbus shield
	3	Modbus (A)
X4 Direction / impulse	1	Pulse / Alarm*
	2	Pulse / Alarm*
	3	Direction input
	4	GND
X5 Power output 1	1	I- Active*
	2	I+ Active*
X6 Power output 2	1	I- Active*
	2	I+ Active*

\* All analog outputs are galvanically isolated.

## Modbus

If the sensor is used at the end of the Modbus system a bus termination is required. Please connect the enclosed 120R resistor to the terminals, Pin 1 and 3 of "X2" connector.

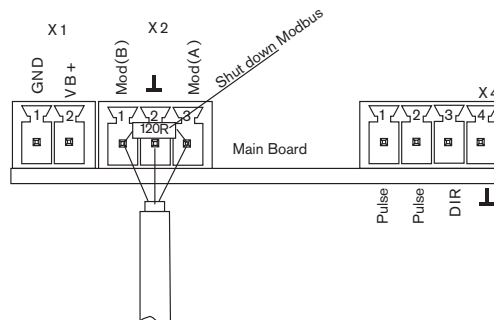

## Ordering chart for air with operating pressure of 6 barg - heavy duty version

Pipe connection	Inner diameter of pipe	Flow range	Overall length	Item no.
R 1/2"	16.1 mm	up to 80 Nm <sup>3</sup> /h <sup>4)</sup>	300 mm	773 511
R 3/4"	21.7 mm	up to 160 Nm <sup>3</sup> /h <sup>4)</sup>	475 mm	773 512
R 1"	27.3 mm	up to 270 Nm <sup>3</sup> /h <sup>4)</sup>	475 mm	773 513
R 1 1/4"	36.0 mm	up to 490 Nm <sup>3</sup> /h <sup>4)</sup>	475 mm	773 514
R 1 1/2"	41.8 mm	up to 670 Nm <sup>3</sup> /h <sup>4)</sup>	475 mm	773 515
R 2"	53.1 mm	up to 1100 Nm <sup>3</sup> /h <sup>4)</sup>	475 mm	773 516

<sup>4)</sup> Index N: Standard condition, flow rate referred to 0 °C and 1.013 bar(a)  
Calibration for another flow range, other gases and/or operating pressure on request.

Dimensions [mm] - standard version

Threaded

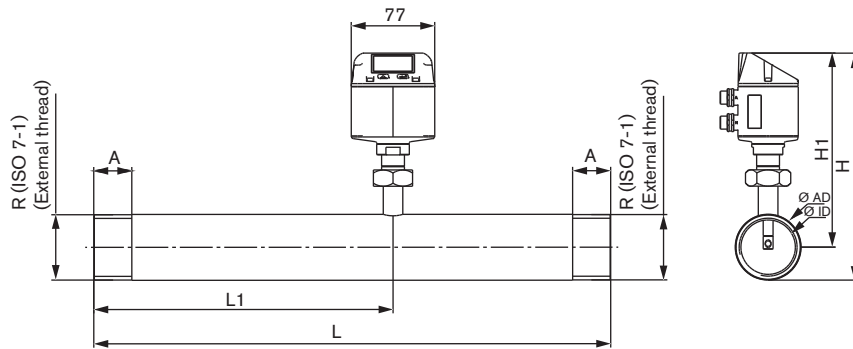

Measuring distance		ØAD Pipe	ØID Pipe	L	L1	H	H1	A
Inch	DN	mm	mm	mm	mm	mm	mm	mm
1/2	15	21.3	16.1	300	210	176.4	165.7	20
3/4	20	26.9	21.7	475	275	179.2	165.7	20
1	25	33.7	27.3	475	275	182.6	165.7	25
1 1/4	32	42.4	36	475	275	186.9	165.7	25
1 1/2	40	48.3	41.9	475	275	186.9	165.7	25
2	50	60.3	53.1	475	275	186.9	165.7	30

Flange

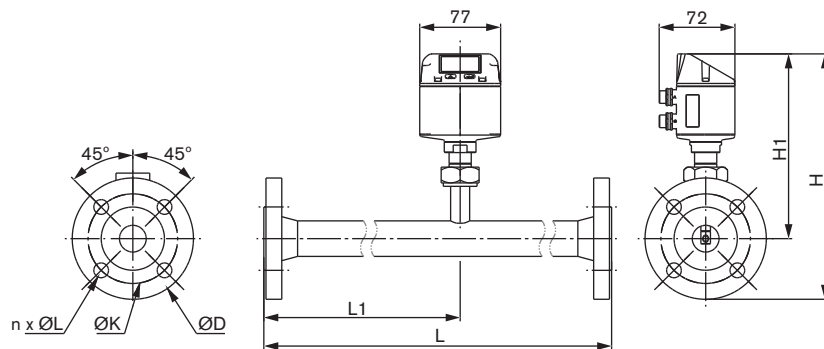

Measuring distance		ØAD Pipe	ØID Pipe	L	L1	H	H1	ØD	ØK	n x ØL
Inch	DN	mm	mm	mm	mm	mm	mm	mm	mm	mm
1/2	15	21.3	16.1	300	210	213.2	165.7	95	65	4 x 14
3/4	20	26.9	21.7	475	275	218.2	165.7	105	75	4 x 14
1	25	33.7	27.3	475	275	223.2	165.7	115	85	4 x 14
1 1/4	32	42.4	36	475	275	235.7	165.7	140	100	4 x 18
1 1/2	40	48.3	41.9	475	275	240.7	165.7	150	110	4 x 18
2	50	60.3	53.1	475	275	248.2	165.7	165	125	4 x 18
2 1/2	65	76.1	68.9	475	275	268.2	175.7	185	145	8 x 18
3	80	88.9	81.9	475	275	275.7	175.7	200	160	8 x 18

## Dimensions [mm] - heavy duty version

## Threaded

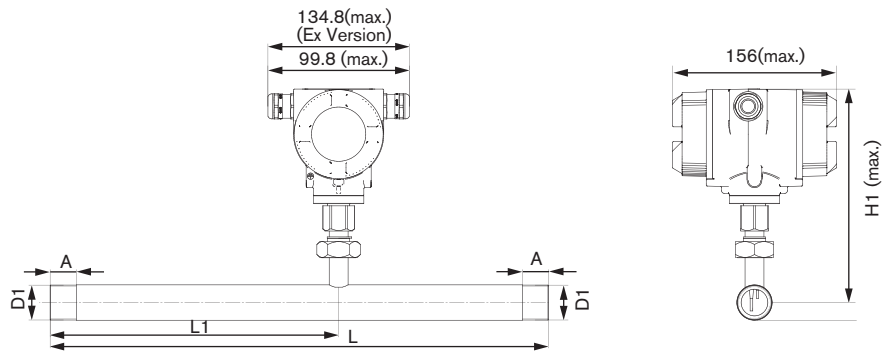

Connection thread Inch	ØAD Pipe mm	ØID Pipe mm	L mm	L1 mm	H mm	H1 mm	A mm
R 1/2	21.3	16.1	300	210	176.4	165.7	20
R 3/4	26.9	21.7	475	275	179.2	165.7	20
R 1	33.7	27.3	475	275	182.6	165.7	25
R 1 1/4	42.4	36	475	275	186.9	165.7	25
R 1 1/2	48.3	41.9	475*	275	186.9	165.7	25
R 2	60.3	53.1	475*	275	186.9	165.7	30

## Flange

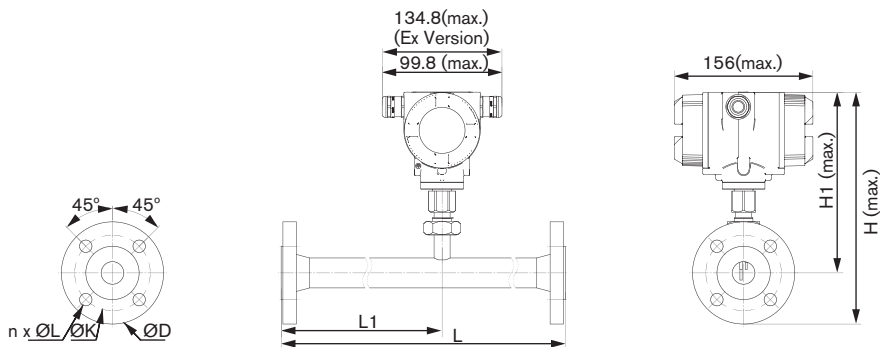

Measuring distance DN	ØAD Pipe mm	ØID Pipe mm	L mm	L1 mm	H mm	H1 mm	Flange DIN EN 1092-1		
							ØD mm	ØK mm	n x ØL mm
15	21.3	16.1	300	210	213.2	165.7	95	65	4 x 14
20	26.9	21.7	475	275	218.2	165.7	105	75	4 x 14
25	33.7	27.3	475	275	223.2	165.7	115	85	4 x 14
32	42.4	36	475	275	235.7	165.7	140	100	4 x 18
40	48.3	41.9	475	275	240.7	165.7	150	110	4 x 18
50	60.3	53.1	475	275	248.2	165.7	165	125	4 x 18

**Note**

You can fill out the fields directly in the PDF file before printing out the form.

**Request for Quotation**

▶ Please complete and send to your nearest Bürkert sales centre\*

Company	Contact person
Customer no.	Department
Address	Phone/Fax
Postcode/Town	E-mail

Quantity  required delivery date

Ausführung  Standard  Heavy duty

**Operating Data**

Gas:  Air  Argon  Nitrogen  Methane  
 Oxygen  Hydrogen  Carbon dioxide  Natural gas  
 Other gas:

Max. flow rate:   m<sup>3</sup>/h  l/min Reference conditions:  N: 0 °C, 1013 mbar(a)  
 (Add-on price for special flow range)  S: 20 °C, 1000 mbar(a)

Other unit

Operating pressure:

Ambient temperature:  °F

Gas temperature:  °F

Pipe connection:  ½" external  ¾" external  1" external  Flange:   
 1 ¼" external  1 ½" external  2" external  Other:

Optionen:  Free of oil and fat, without O2 certificate  
 Free of oil and fat, with O2 certificate  
 High pressure up to 40 bar

**Comments / Sketch**

To find your nearest Bürkert facility, click on the orange box



[www.burkert.com](http://www.burkert.com)

In case of special application conditions, please consult for advice.

Subject to alteration.  
 © Christian Bürkert GmbH & Co. KG

1710/10\_EU-en\_00895237