

# LAYER SERIES

## 2023



**LAYER**设计概念来自于层叠的设计表现,通过不同的坐壳型式与不同种类椅脚配置,从原本基础造型上叠加产生更多变化,适用于多种类空间:如餐厅、办公环境、居家生活、酒店环境、教育学习环境、商业空间等等,LAYER都能够组合与配置出合适选择.目的是使塑料材料减量,降低对石化塑料的依赖并且减少碳足迹,在大量生产之余考虑不伤害环境的做法,让我们可以留给下一代更加美好的生活环境。

LAYER design concept from the design of the cascade performance, through different seat shell type with different kinds of chair legs configuration, based on modelling from overlay produces more change, suitable for variety of space: such as restaurants, office, home-living, hotel, education, learning environment, commercial space, etc., LAYER combination and configuration can be the right choice. The goal is to reduce the amount of plastic materials, reduce the dependence on petrochemical plastics and reduce the carbon footprint, and consider the environmentally friendly practices in mass production so that we can leave a better living environment for the next generation.





# 更贴合脊背 舒适感 PLUS



高椅背贴合身体曲线,为脊柱提供不缺席的支持,向内收拢的椅面符合人体工学,搭配稳重木脚,有效提升坐感.内衬与椅壳的撞色搭配,提升空间格调。

The high back of the chair fits the curve of the body to provide support for the spine without absence. The inward folding of the chair surface is ergonomic and matched with stable wooden feet to effectively enhance the sense of sitting. The inner lining is matched with the chair shell to enhance the space style.



丰富椅脚搭配, 随需而变,  
体现LAYER的更多用武之地。

Rich chair foot matching, change as needed,  
More application of LAYER.

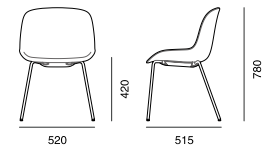

LAYER WS

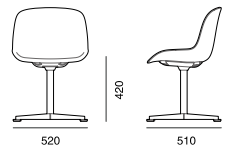

LAYER WF

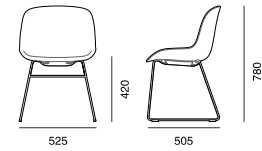

LAYER WX

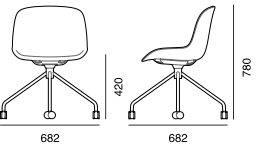

LAYER WK

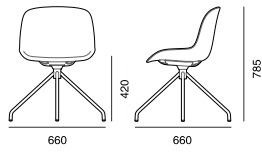

LAYER WD

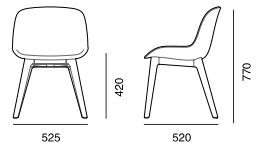

LAYER WM

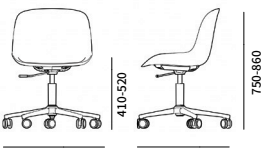

LAYER WZ

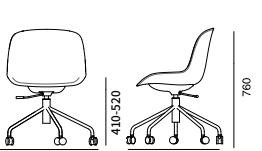

LAYER WL

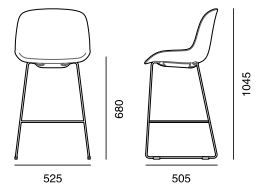

LAYER WC

## 椅面配置



## 塑壳配色



莱姆绿



森林绿



风暴灰



雪花白



秘境黑



歌剧红

## 椅脚配置



type-X

type-S

type-Z

type-F

type-K

type-D

type-M

type-L

type-C



**LITE LAYER**的设计来自于LAYER的延伸系列,整体设计更加小巧,延伸了LAYER零件无螺丝设计结构的同时又使得整个系列的选择性更加丰富,满足不同空间,人群,场景的使用需求,使得整个系列更加完整,优雅的外观,丰富的色彩更是点缀了各个场景。

The design of LITE LAYER comes from the extension series of LAYER, and the overall design is more compact. While extending the screw-free design structure of LAYER parts, the selection of the whole series becomes richer. That meeting the use requirements of different spaces, people and scenes, making the whole series more complete and elegant on the appearance. Multiple colors embellish each scene.



**LITE LAYER**





# 打破空间束缚 演绎优雅视觉中心

将LITE LAYER自身优雅的气质传递至整套座椅系列。

搭配多样椅脚,从办公空间到家庭场景,在满足优美线条的同时打破空间束缚。

The elegant temperament of LITE LAYER is transferred to the whole series of seats.

With a variety of chair feet, from office space to home scenes, to meet the beautiful lines at the same time break space constraints.



**LITE LAYER**纤细的金属脚和变窄的后背使得它在家族系列中最轻、最窄,让LITE LAYER“座”如其名,可以堆叠,收纳,在培训空间、临时会议空间,会餐空间使用非常广泛。

LITE LAYER's slim metal feet and narrow back make it the lightest and narrowest in the family. LITE LAYER "seat" can be stacked and stored as its name suggests. It is widely used in training Spaces, temporary meeting Spaces, and dining Spaces.

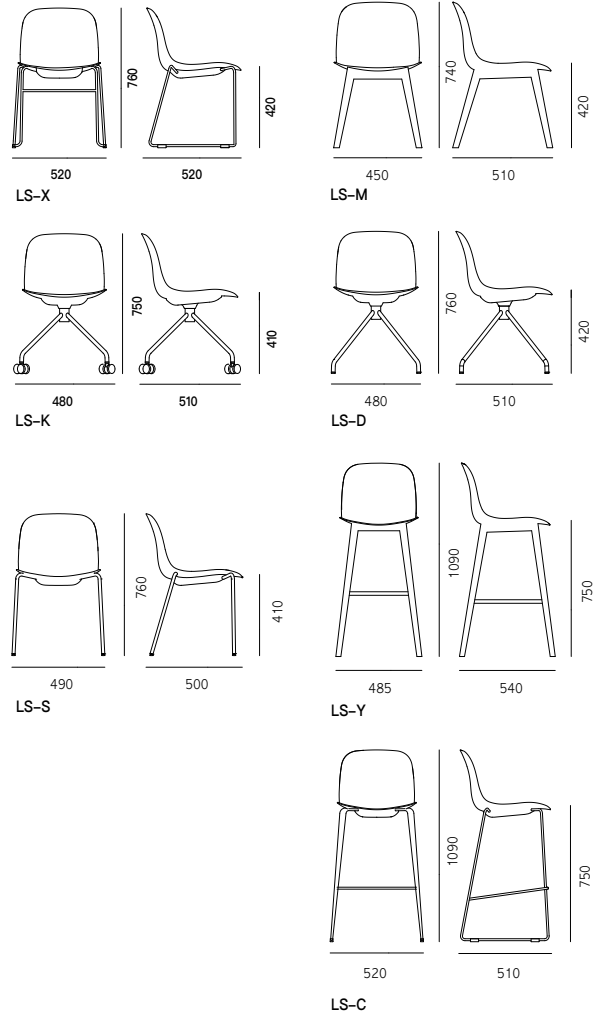

## 椅面配置



## 塑壳配色



## 椅脚配置



type-X

type-S

type-D

type-K

type-M

type-C

type-Y



曲木板椅在原有塑料椅身的材质上，我们新开发了曲木板的配置。通过木皮纹理精心选择，加上对原有3D曲线的巧妙再勾勒，现在这把**LITE LAYER**曲木椅区别于原有对其的印象，体现一种非凡的新感受。

In the original plastic chair body material, we developed a new configuration of curved wood. Through the careful selection of wood skin texture and the clever re-outline of the original 3D curve, the LITE LAYER curved wood chair is different from the original impression of it, reflecting an extraordinary new feeling.



# LITE LAYER 曲木板



# 新材质，新感受

在如今空间的设计越来越表达亲近自然的主题时，纯木纹的椅子就更能结合空间，传达出一种趣艺天然的感受。

In today's space design more and more express the theme of close to nature, pure wood grain chair can be more combined with the space, convey a natural feeling of fun art.

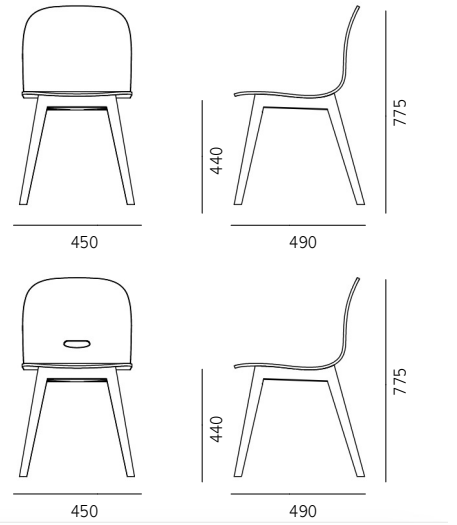

**LITE LAYER**不但满足了这样的审美感受，同时轻量化的设计也为使用过程的移动提供了便利。

The LITE LAYER not only satisfies this aesthetic feeling, but also provides a lightweight design to facilitate the movement of the use process.

---

### 椅面配置



---

### 椅脚配置



type-X

---

### 木纹配置

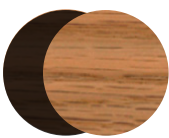

椅面

红橡木皮，胡桃木皮



椅脚

红橡木实木，红橡胡桃本色



如何使一把椅子适合更多的空间和满足更多的需求是我们一直在探索的方向。LITE LAYER以自身原有轻盈的形态灵活运用与多种空间，而这次我们为其配备了更完善的系统，包括可360度旋转的写字板，杯架和挂勾等巧思配置，使得LITE LAYER的运用可以延展到需求日益增长的培训和多功能空间中去。

How to make a chair fit more space and meet more needs is the direction we have been exploring. litelayer is flexible in its original light form and can be used in a variety of Spaces. This time, we equipped it with a more complete system, including a 360-degree rotating tablet, cup holder and hook, so that the application of litelayer can be extended to the growing demand for training and multifunctional Spaces.



## LITE LAYER 培训椅



# 延续轻盈体验，增加更多功能

**LITE LAYER**在原有手柄升降的基础上我们还配备了可以另选的线控升降操作按钮。小巧的结构更具隐蔽性和操作的舒适性。

LITE LAYER also includes optional wire lift buttons in addition to the original handle lift. Compact structure more concealment and operation comfort.



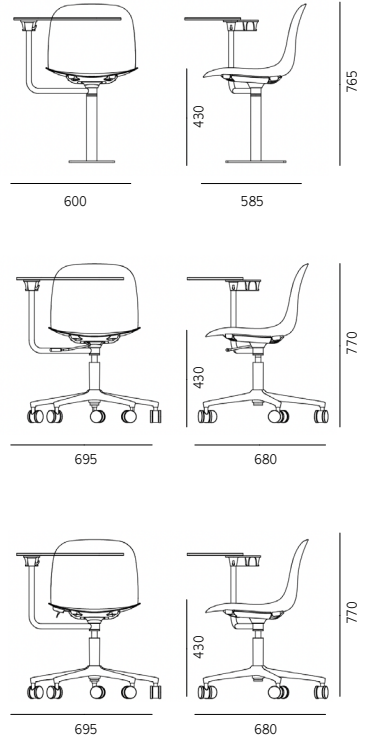

椅壳和椅座演绎高级色彩碰撞，  
打破会议室严肃氛围，点亮空间活力。

Chair shell and seat interpretation of senior color collision,  
Break the serious atmosphere of the meeting room and  
light up the vitality of the space.

## 椅面配置



## 塑壳配色



莱姆绿



森林绿



风暴灰



雪花白



秘境黑



歌剧红

## 椅脚配置



LS-TF



LS-TZ



LS-TX

# LAYER / LITE LAYER

## 零件无螺丝拆装机构设计

### 零件



### 安装方法



①

将底脚架卡进卡槽里

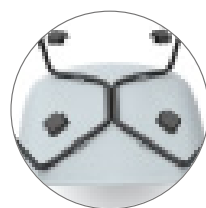

②

卡扣对准脚架



③

卡扣卡进脚架钢管



④

卡扣沿着钢管往卡槽里推



⑤

分别将四个卡扣推进卡槽里

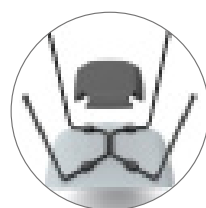

⑥

底盖对准脚架

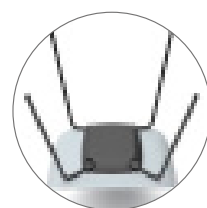

⑦

将底罩卡进锁扣



⑧

安装完毕



在**LAYER**的家族中我们非常开心的又加入了**PLUS**系列。更舒适宽松的椅身和更加多的椅脚搭配方式，为layer的家族增添了新的活力。

We are very happy to add the PLUS series to the LAYER family. More comfortable and loose chair body and more collocation of chair feet add new vitality to layer's family.



# LAYER PLUS



**更多舒适，更多可能**

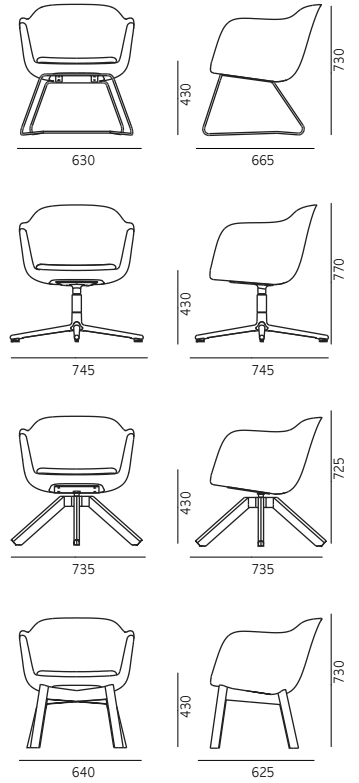

我们这次为**LAYER PLUS**特别设计了4种脚型。其中全铝的交叉金属脚更显商务气质，而两款实木的脚型则更多休闲自然的气息。

We specially designed 4 foot types for LAYER PLUS this time. The all-aluminum cross-metal feet are more businesslike, while the two solid wood feet are more casual and natural.

## 椅面配置



## 椅脚配置



Layer Plus-AX

Layer Plus-AU

Layer Plus-AM1

Layer Plus-AM2

\_\_\_\_, IN LIFE



[www.ufou.com](http://www.ufou.com)